

MEDICAL EQUIPMENT IV - 2013

MECHANICAL VENTILATORS

Prof. Yasser Mostafa Kadah

Mechanical Ventilator

- A ventilator is a machine, a system of related elements designed to alter, transmit, and direct energy in a predetermined manner to augment or replace patient's muscles in performing the work of breathing
 - ▣ Energy in: electricity or compressed air
- Basic functions in all ventilators
 - ▣ Power input
 - ▣ Power transmission or conversion
 - ▣ Control scheme
 - ▣ Output
 - ▣ Alarms

Anatomy of Respiratory Tract

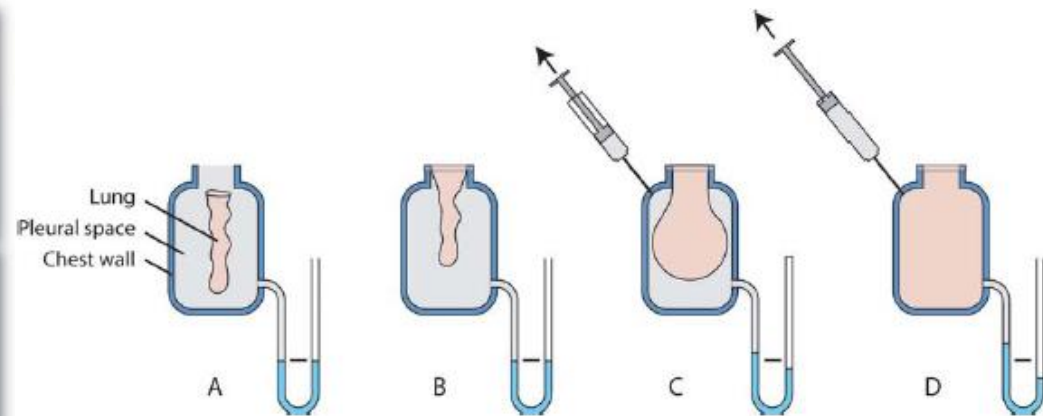
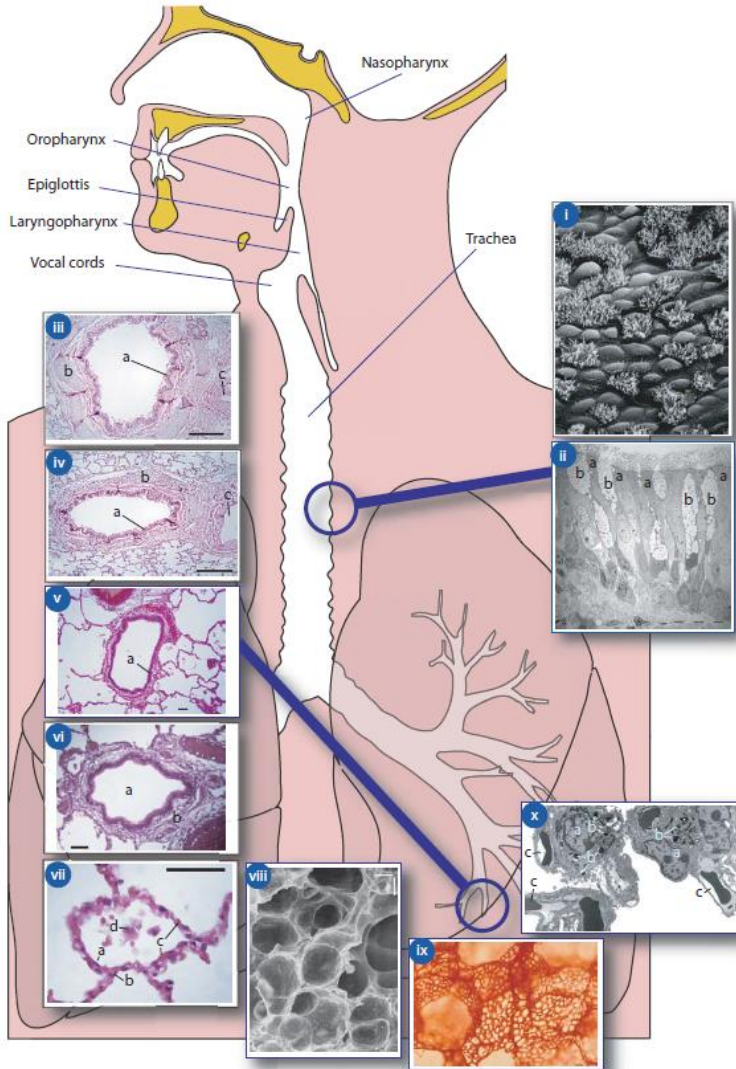

Surface Tension Forces within the Lung

- The pressure within a truly spherical alveolus (P_A) would normally be calculated as twice the surface tension (T_s) divided by the alveolar radius (r):

$$P_A = \frac{2 \times T_s}{r}.$$

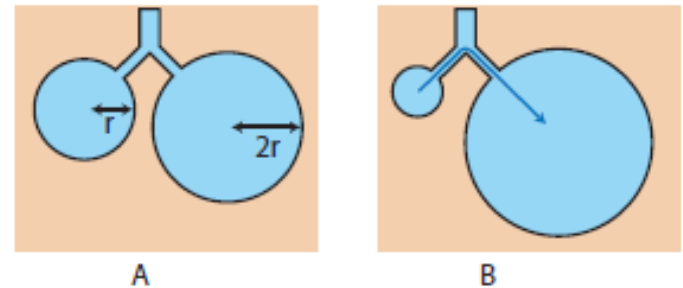

- If T_s is constant, all of the alveoli in a lung would empty into one huge alveolus!
- Fortunately, surface tension is *not* constant: surfactant reduces the surface tension in proportion to the change in the surface area
- Gas flows from larger to smaller alveoli

Lung Compliance

- The 'expandability' of the lung is known as its compliance.
 - ▣ A high compliance means that the lung expands easily
 - ▣ Compliance is generally given by $\text{Volume}/\text{Pressure}$
- For a delivered tidal volume of V mL:
 - ▣ Dynamic compliance is given by V/P_{peak}
 - ▣ Static compliance is given by V/P_{plat}

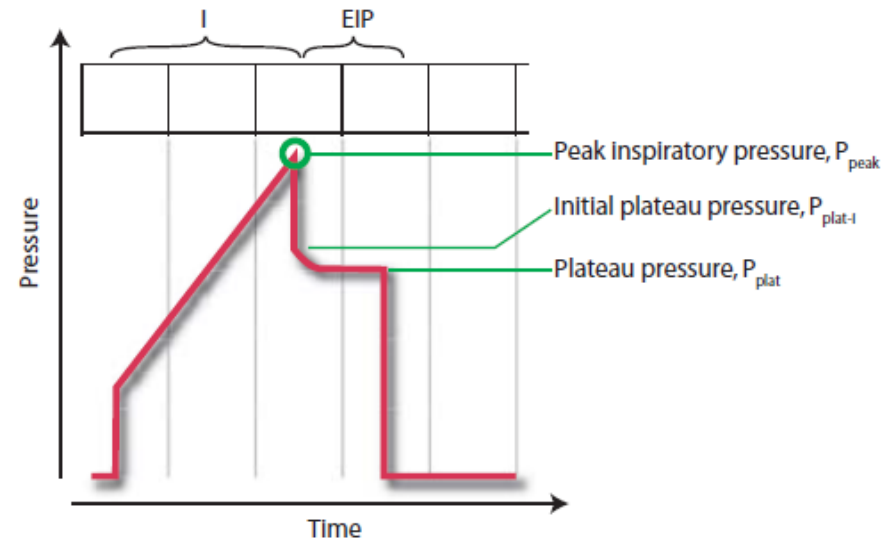
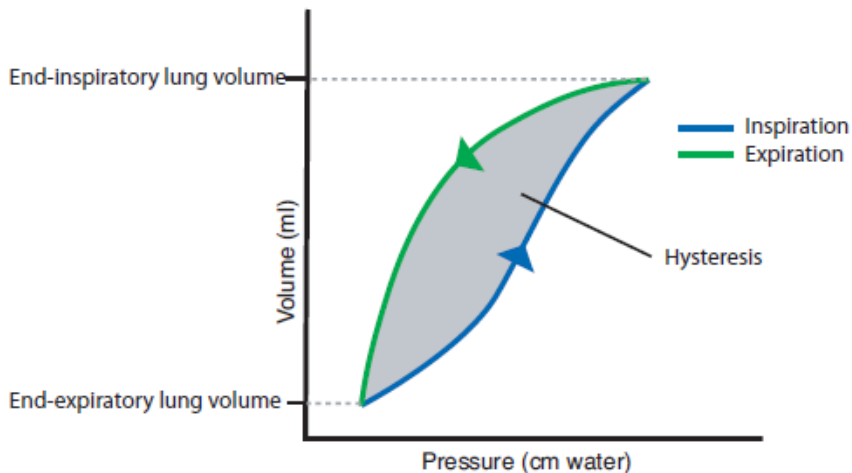

Two-Compartment Model of Static and Dynamic Compliance

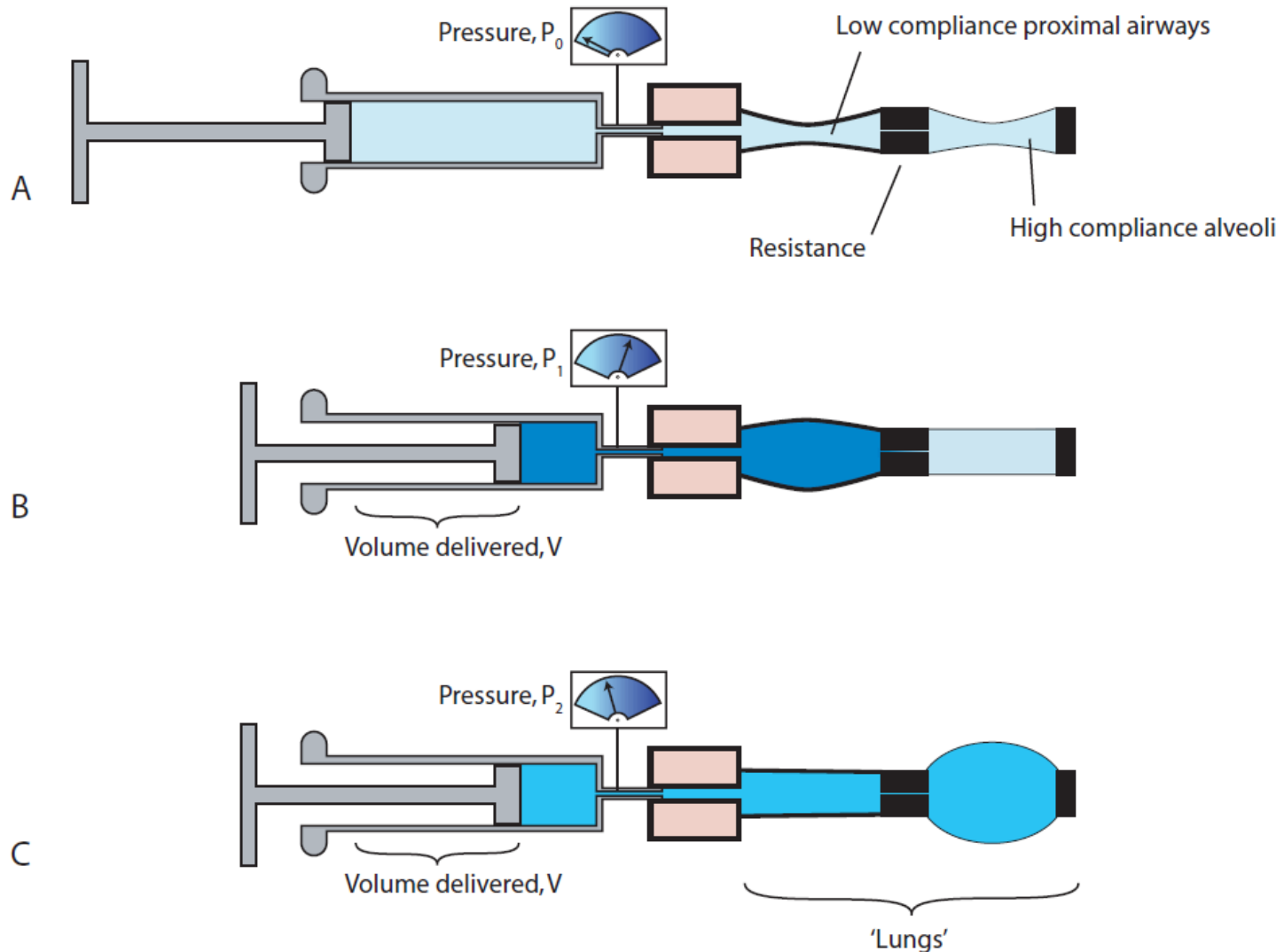

Gas Exchange

- Speed of diffusion is determined by:
 - ▣ partial pressure gradient
 - ▣ thickness of barrier
 - ▣ solubility of oxygen in barrier
- Contact time is inversely proportional to the cardiac output
 - ▣ At rest is normally 0.75 s
 - ▣ At sea level, only 0.25 s is needed

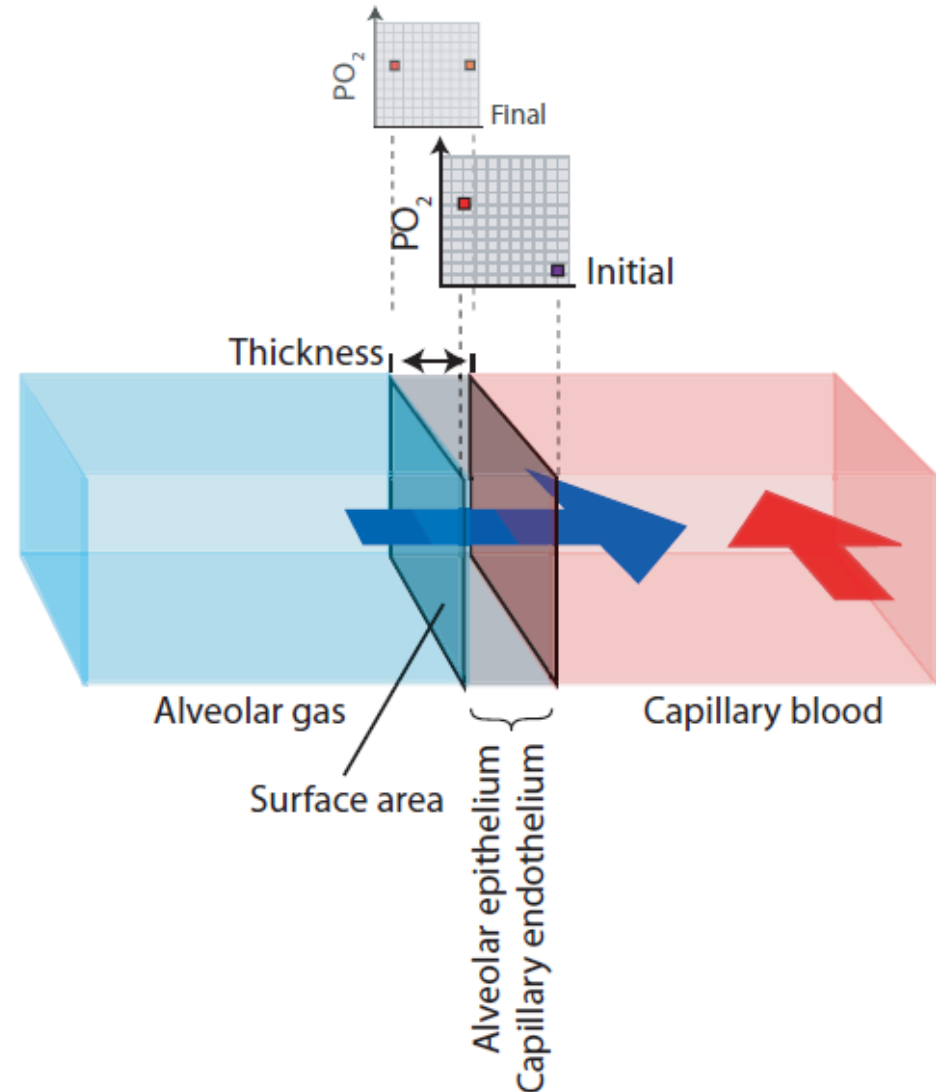

Devices for Administration of Oxygen

- A: Nasal cannulae
- B: Variable performance mask
- C: Variable performance mask with reservoir
- D: Fixed performance mask



Venturi Mechanism

- If oxygen is supplied to the venturi device at the correct flow rate, air will be entrained through the vents to provide an air/oxygen mixture with a specific oxygen concentration

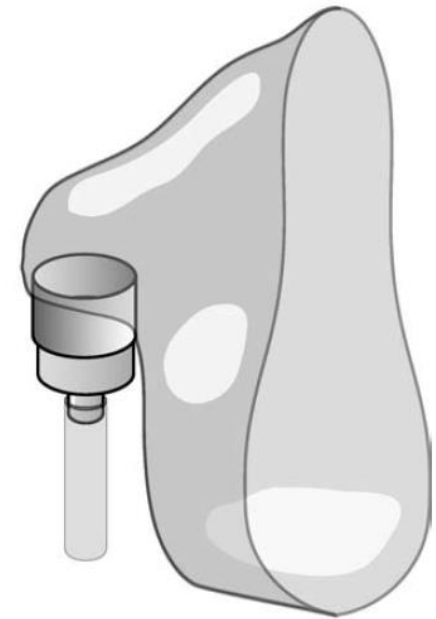
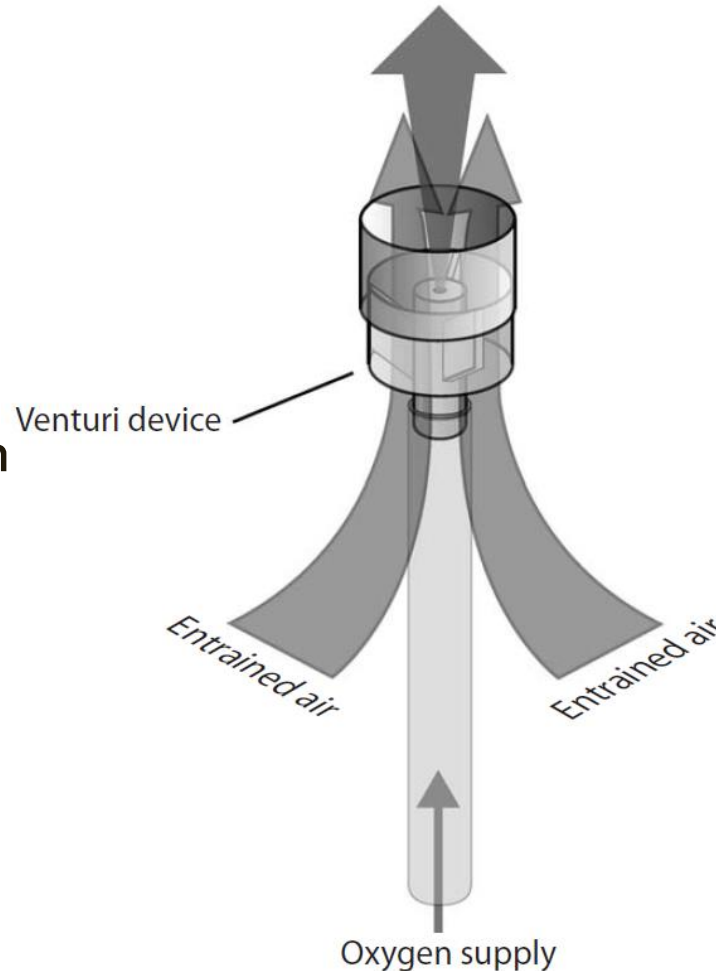

Non-Invasive Ventilation (NIV) vs. Continuous Positive Airway Pressure (CPAP)

- NIV: PEEP or EPAP
 - ▣ Positive end-expiratory pressure (PEEP)
 - ▣ Expiratory positive airway pressure (EPAP)

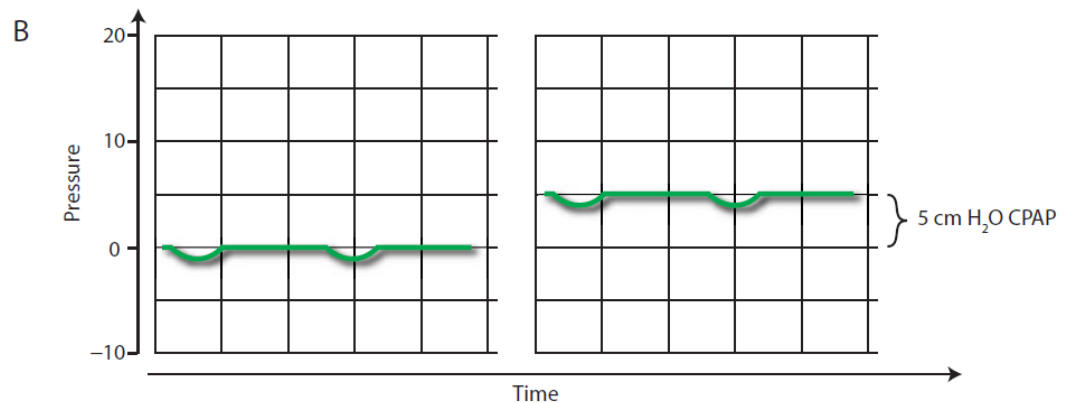
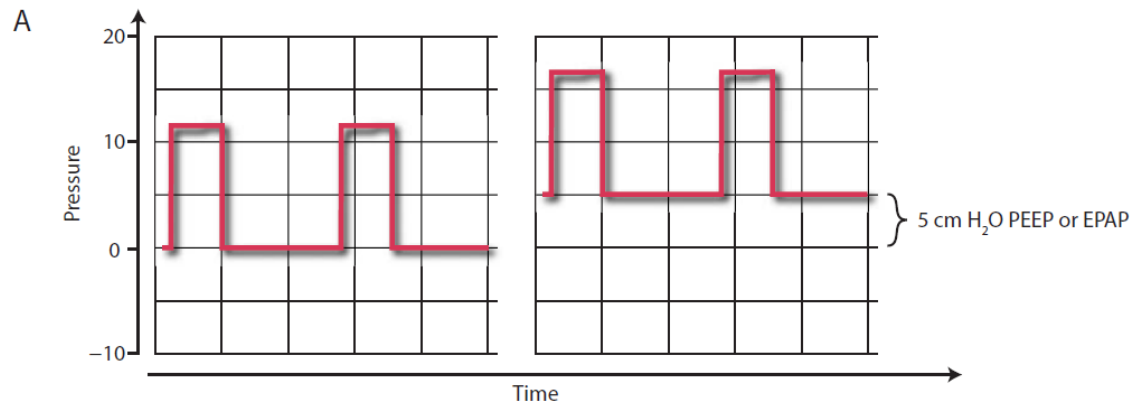

CPAP Circuit

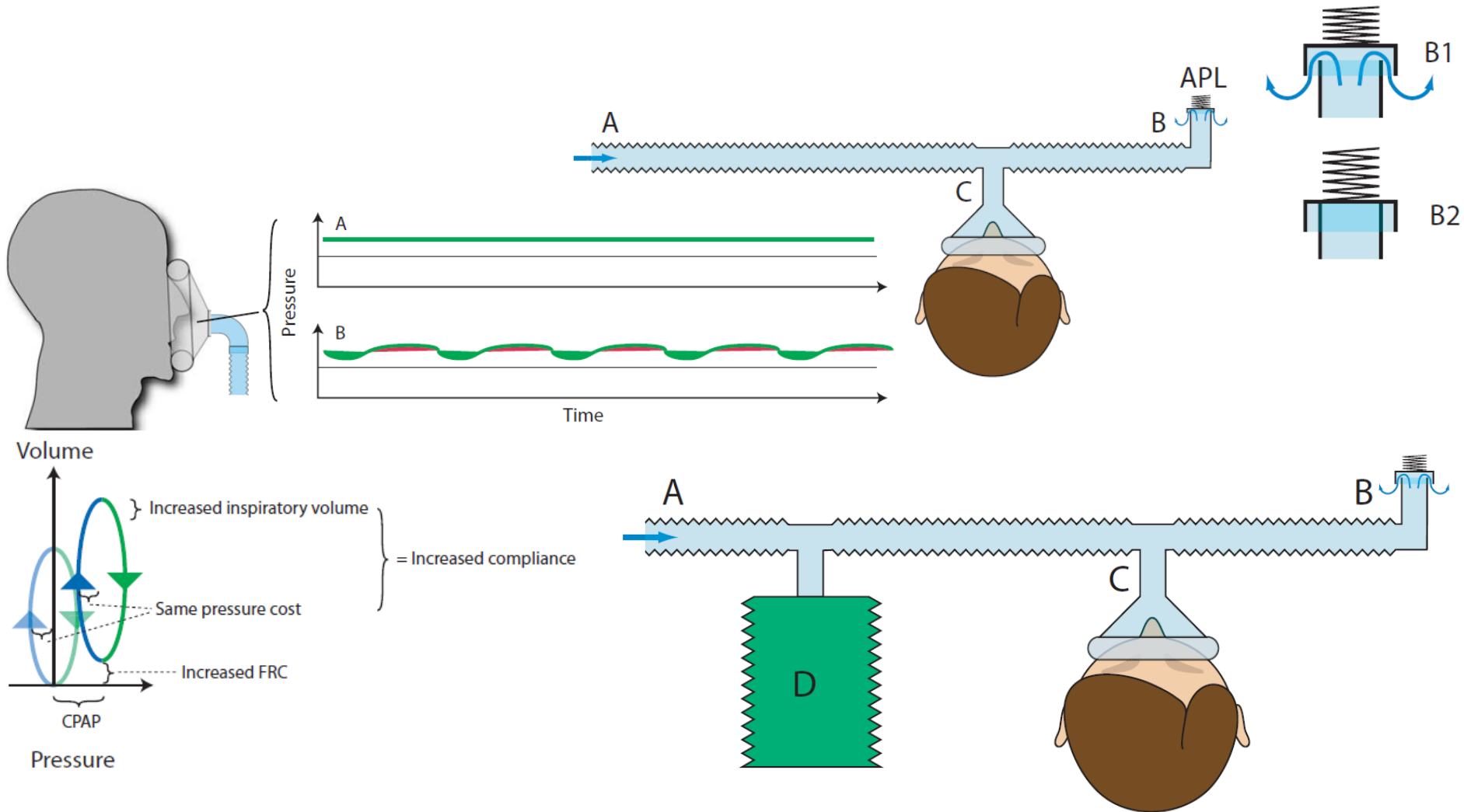

NIV Circuit

- Unlike ventilator circuits used for anesthesia or critical care which have two limbs, one taking fresh gas to the patient and a second returning expired gas to the ventilator, breathing circuits for non-invasive ventilation (NIV) only have one limb for taking fresh gas to the patient

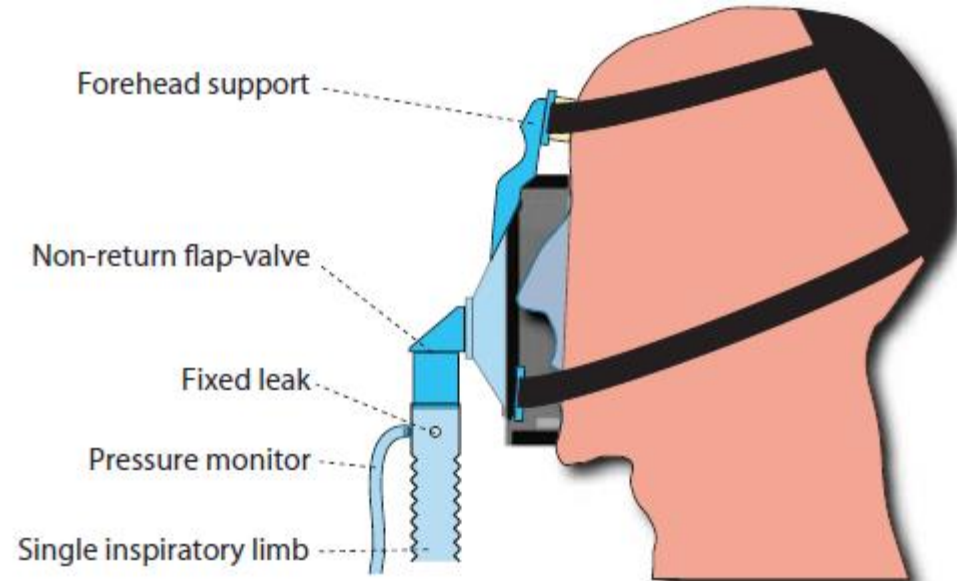

Respiratory Cycle

$$T_I + T_E = T_C.$$

$$T_I = T_{I\text{flow}} + T_{I\text{pause}}$$

$$f = \frac{60}{T_C}.$$

$$\frac{T_I}{T_I + T_E} \times 100 = \frac{T_I}{T_C} \times 100 = \text{Duty cycle (\%)}.$$

$$f = \frac{\dot{V}}{V_T}.$$

$$\dot{V}_I = \frac{V_T}{T_I}.$$

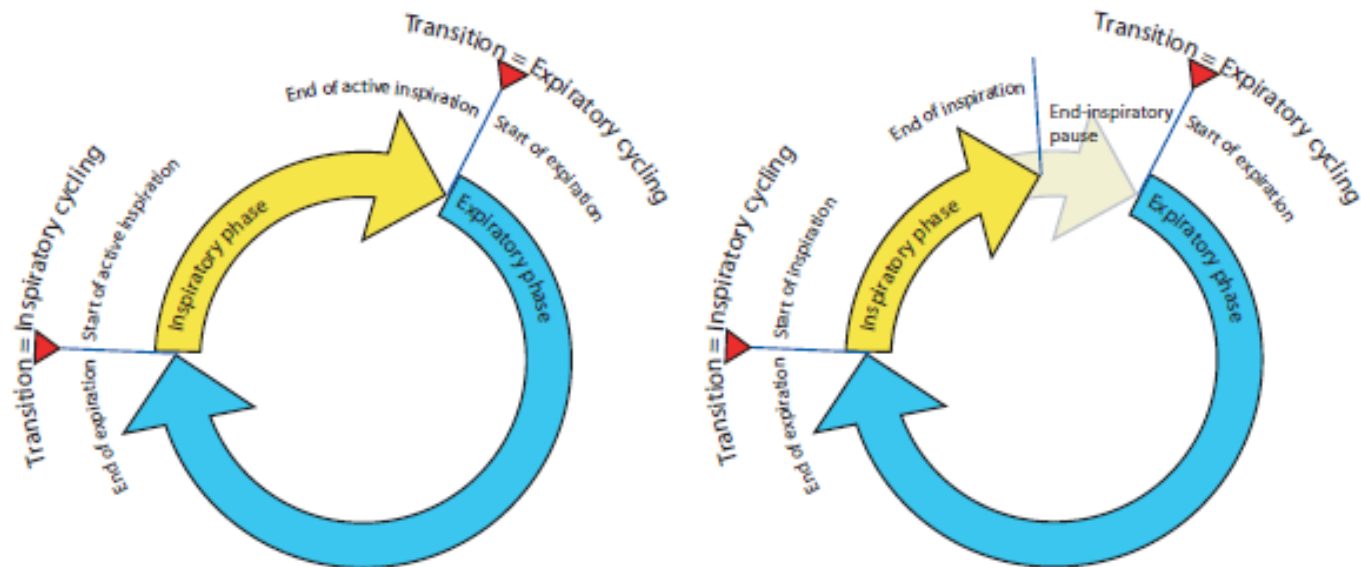

Trigger, Limit, Cycle, and Baseline Variables

- Trigger variable is one that is measured and used to start inspiration
- Limit variable is one that can reach and maintain a preset value before inspiration ends (i.e., does not end respiration)
- Cycle variable is one that is measured and used to end respiration
- Baseline variable is the parameter controlled during expiration
 - ▣ Pressure control is most practical and used in all modern ventilators

Inspiratory vs. Expiratory Cycling

- Exactly when a phase transition occurs can either be determined by the ventilator or by the patient.
- Inspiratory cycling: time or spontaneous (patient)
- Expiratory cycling: time or flow
- Inspiratory triggering
 - ▣ Volume
 - ▣ Pressure

Mandatory, Spontaneous and Triggered Inspiratory Cycling

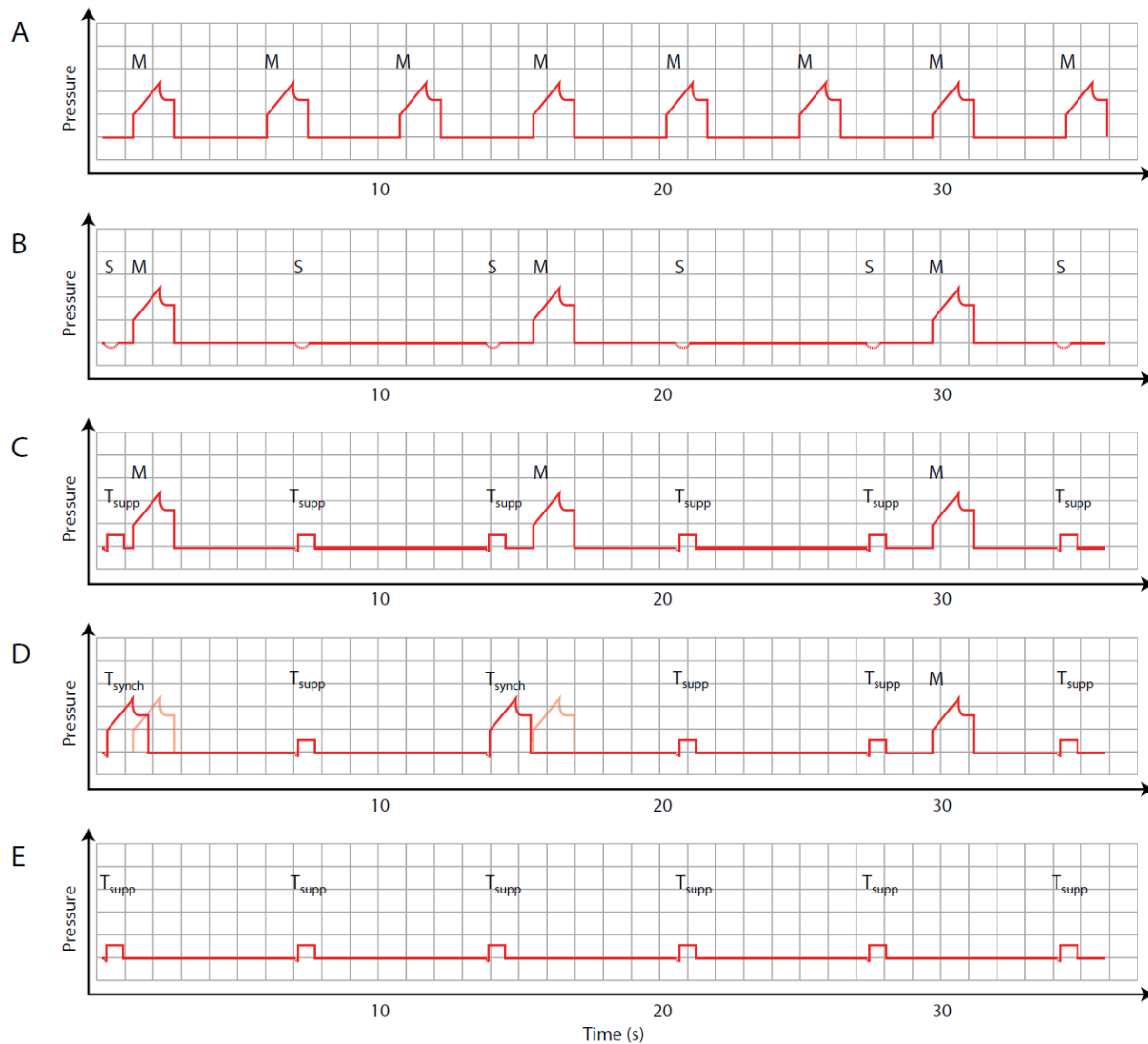

Classification of Breath Types

Table 5.1 Comparison of 'volume-controlled' and 'pressure-controlled' breaths

	Volume	Pressure
Tidal volume	Fixed	Variable
Airway pressure	Variable	Fixed
Minute volume	Set	Measured
Inspiratory flow	Constant	Decelerating

Table 5.2 Classification of breath types based on the control of inspiratory and expiratory cycling

Inspiratory cycling	Expiratory cycling	Inspiratory support	Breath type	Example
Ventilator	Ventilator	Yes	Mandatory	IPPV breath
Patient	Ventilator	Yes	Triggered	Pressure support
Patient	Patient	No	Spontaneous	CPAP breath

Table 5.3 Classification of mode types based on the type of breaths available within the mode

Breath types	Mode	Examples
Mandatory only or mandatory + spontaneous	Mandatory	IPPV
Triggered only	Triggered	Pressure support
Spontaneous only	Spontaneous	CPAP
Mandatory + triggered	Hybrid	SIMV, Assist/control

Volume- or Pressure-Driven Inspiration

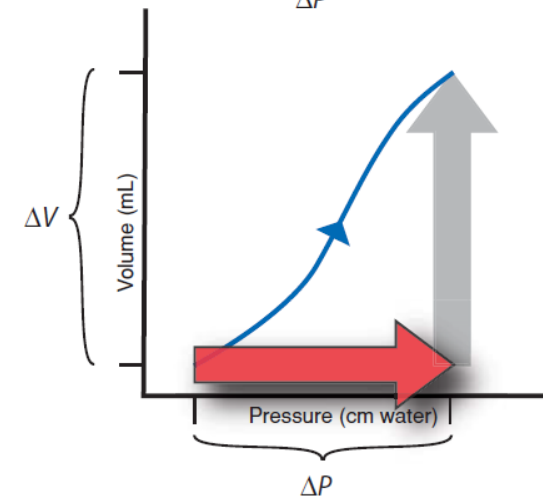
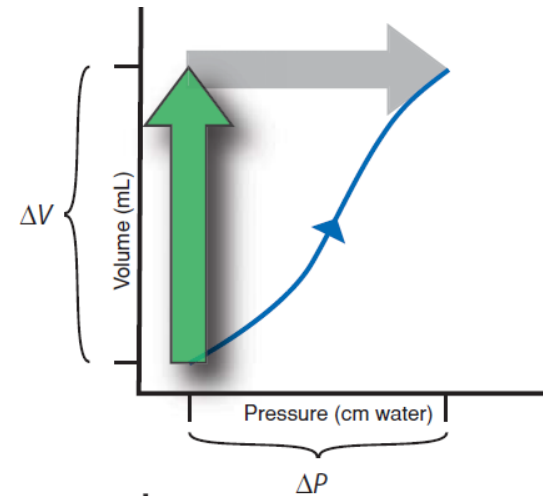
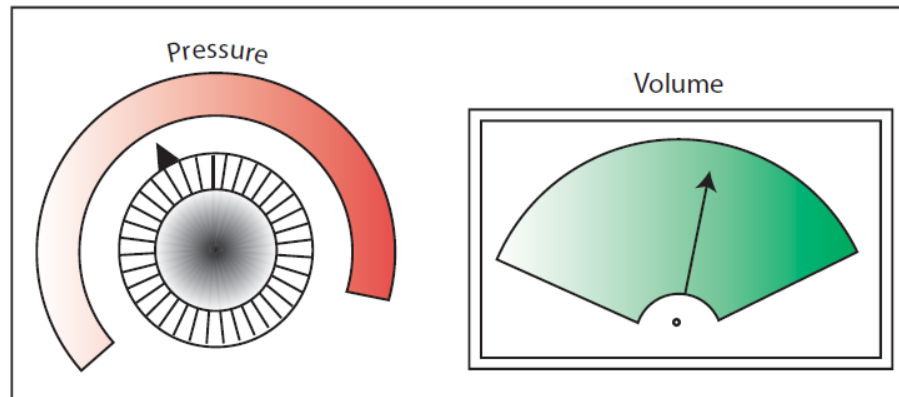
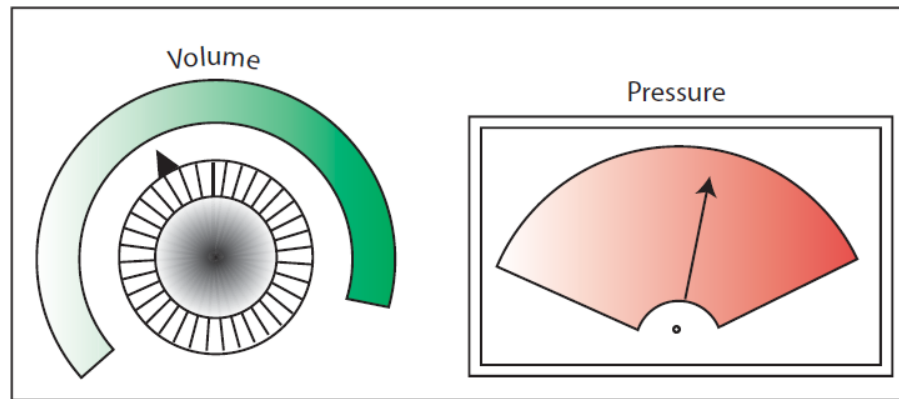

Classifying Modes of Mechanical Ventilation

- A “mode” of mechanical ventilation can be generally defined as a predetermined pattern of interaction between a ventilator and a patient.
 - ▣ There are over 100 names for modes of ventilation on commercially available mechanical ventilators.
 - ▣ Neither the manufacturing community nor the medical community has developed a standard taxonomy for modes

Classification of Modes

- In mandatory breaths (if present)
 - ▣ What determines inspiratory cycling?
 - ▣ What drives inflation and what is the breath targeted to or limited by?
 - ▣ Is feedback intra-breath or inter-breath?
 - ▣ What determines expiratory cycling?
- In triggered breaths (if present)
 - ▣ What breath types are present? Mandatory-pattern, supported or both?
 - ▣ In supported breaths (if present), what drives inflation (control parameter) and what is the breath targeted to or limited by?
 - ▣ Is feedback intra-breath or inter-breath?
 - ▣ What determines expiratory cycling?
- Are spontaneous breaths accommodated and if so, when?

Mandatory Modes of Ventilation

Mandatory breaths

Inspiratory cycling	Time	Time	Time	Time
Control	Volume ^a	Volume	Volume	(Pressure)
Target/Limit	-	-	Pressure-limited	Volume-targeted
Feedback	-	-	Intra-breath	Inter-breath
Expiratory cycling	Time	Time	Time	Time ^b

Triggered breaths

Types	None	None	None	None
-------	------	------	------	------

Supported breaths

Control	-	-	-	-
Target	-	-	-	-
Feedback	-	-	-	-
Expiratory cycling	-	-	-	-

Spontaneous breaths

During mandatory inspiration	Not accommodated ^c	Not accommodated	Not accommodated	Accommodated
Otherwise	Not accommodated	Accommodated	Not accommodated	Accommodated

Synonyms	IPPV (Draeger ^d), Controlled Mandatory Ventilation or (historically) Control Mode Ventilation	Intermittent Mandatory Ventilation	IPPV (Draeger ^e)	IPPV (Draeger ^f)
----------	---	------------------------------------	------------------------------	------------------------------

Triggered Modes of Ventilation

Mandatory breaths			
Inspiratory cycling	-	-	-
Control	-	-	-
Target	-	-	-
Feedback	-	-	-
Expiratory cycling	-	-	-
Triggered breaths			
Types	Supported breaths only	Supported breaths only	Supported breaths only
Supported breaths			
Control	Pressure ^a	(Pressure ^b)	(Pressure ^b)
Target/Limit	-	Volume-targeted	Flow and volume
Feedback	-	Inter-breath	Intra-breath
Expiratory cycling	Flow ^c	Flow ^c	Flow ^c
Spontaneous breaths			
During mandatory inspiration	-	-	-
Otherwise	-	-	-
Synonyms	Assisted Spontaneous Breathing (Draeger), Spontaneous mode (Hamilton, Puritan-Bennett), Pressure support (Maquet), CPAP (Respironic), Pressure Support Ventilation (Viasys)	Volume Support (Maquet, Puritan-Bennett)	Proportional assist ventilation, Proportional Pressure Support (Draeger), Proportional Assist Ventilation Plus (Puritan-Bennet)

Hybrid Mode: Assist Control

Mandatory breaths

Inspiratory cycling	Time or trigger	Time or trigger	Time or trigger
Control	Volume	Pressure ^a	(Pressure ^b)
Target	-	-	Volume-targeted
Feedback	-	-	Inter-breath
Expiratory cycling	Time	Time	Time

Triggered breaths

Types	Mandatory-pattern only	Mandatory-pattern only	Mandatory-pattern only
-------	------------------------	------------------------	------------------------

Supported breaths

Control	-	-	-
Target	-	-	-
Feedback	-	-	-
Expiratory cycling	-	-	-

Spontaneous breaths

During mandatory inspiration:	Not accommodated ^c	Accommodated	Accommodated
Otherwise			
Synonyms	IPPV _{Assist} (Draeger ^d), Synchronized Controlled Mandatory Ventilation (Hamilton), Volume Control (Maquet), VCV-A/C (Puritan-Bennett, Respironics), Volume A/C (Viasys)	BIPAP _{Assist} (Draeger), P-CMV (Hamilton), Pressure Control (Maquet), PCV-A/C (Puritan-Bennett, Respironics), Pressure A/C (Viasys)	Adaptive Pressure Ventilation CMV (Hamilton), Pressure Regulated Volume Control (Maquet), VC+ A/C (Puritan-Bennett), Pressure Regulated Volume Control A/C (Viasys), IPPV Assist Autoflow (Draeger)

Hybrid Mode: Synchronized Intermittent Mandatory Ventilation (SIMV)

Mandatory breaths			
Inspiratory cycling	Time or trigger	Time or trigger	Time or trigger
Control	Volume	Pressure ^a	(Pressure ^b)
Target/Limit	–	–	Volume-targeted
Feedback	–	–	Inter-breath
Expiratory cycling	Time	Time	Time
Triggered breaths			
Types	Mandatory-pattern ^c and supported	Mandatory-pattern and supported	Mandatory-pattern and supported
Supported breaths			
Control	Pressure ^d	Pressure ^d	Pressure ^d
Target	–	–	–
Feedback	–	–	–
Expiratory cycling	Flow ^e	Flow ^e	Flow ^e
Spontaneous breaths			
During mandatory inspiration	Not accommodated	Accommodated	Accommodated
Otherwise	Only if support is OFF.	Only if support is OFF.	Only if support is OFF.
Synonyms	SIMV (Draeger, Hamilton), SIMV (VC) + PS (Maquet), VCV-SIMV (Puritan-Bennett, Respironics), Volume SIMV (Viasys)	P-SIMV (Hamilton), SIMV(PC) + PS (Maquet), PCV-SIMV (Puritan-Bennett, Respironics), Pressure SIMV (Viasys)	SIMV + Autoflow (Draeger), Adaptive Pressure Ventilation SIMV (Hamilton), SIMV (PRVC) + PS (Maquet), VC+ SIMV (Puritan-Bennett), PRVC SIMV (Viasys)

Hybrid Mode: Bi-Level Ventilation

Mandatory breaths				
Inspiratory cycling	Time or trigger	Time or trigger	Time or trigger	Time or trigger
Control	Pressure ^a	Pressure ^b	Pressure ^c	Pressure ^d
Target	-	-	-	-
Feedback	-	-	-	-
Expiratory cycling	Time or trigger	Time or trigger	Time or trigger	Time or trigger
Triggered breaths				
Interaction	Mandatory-pattern and supported	Mandatory-pattern and supported	Mandatory-pattern ^e and supported	Mandatory-pattern and supported
Supported breaths				
Control	Pressure ^f	Pressure ^g	Pressure ^h	Pressure ⁱ
Target	-	-	-	-
Feedback	-	-	-	-
Expiratory cycling	Flow ^j	Flow ^j	Flow ^j	Flow ^j
Spontaneous breaths				
During mandatory inspiration	Accommodated	Triggers support to $PEEP + P_{support}$ if this is $> P_{high}$ (Hamilton DuoPAP), $P_{low} + P_{support}$ if this is $> P_{high}$ (Hamilton APRV), or $PEEP_L + P_{supp}$ if this is $> PEEP_H$ (Puritan-Bennett)	Triggers support to $PRES HIGH + PSV$ if $T_{high} PSV$ is activated	Triggers support to PSV above P_{High}
Otherwise	Triggers support	Triggers support to $PEEP + P_{support}$ (Hamilton DuoPAP), $P_{low} + P_{support}$ (Hamilton APRV), or $PEEP_L + P_{supp}$ (Puritan-Bennett)	Triggers support to $PRES LOW + PSV$	Triggers support to PSV above $PEEP$
Synonyms	BIPAP (Draeger)	DuoPAP/APRV (Hamilton), Bi-level (Puritan-Bennett)	APRV/Bi-phasic (Viasys)	Bi-vent (Maquet)

Aerosol Drug Delivery

- Drug delivery directly to the lung through inhalation maximizes effector-site concentration while minimizing side effects and avoiding systemic absorption completely
 - Aerosol delivery is an appropriate method for a range of drugs
- Nebulizers
 - Jet
 - Ultrasonic
 - Vibrating mesh
- Metered-dose inhaler (MDI)

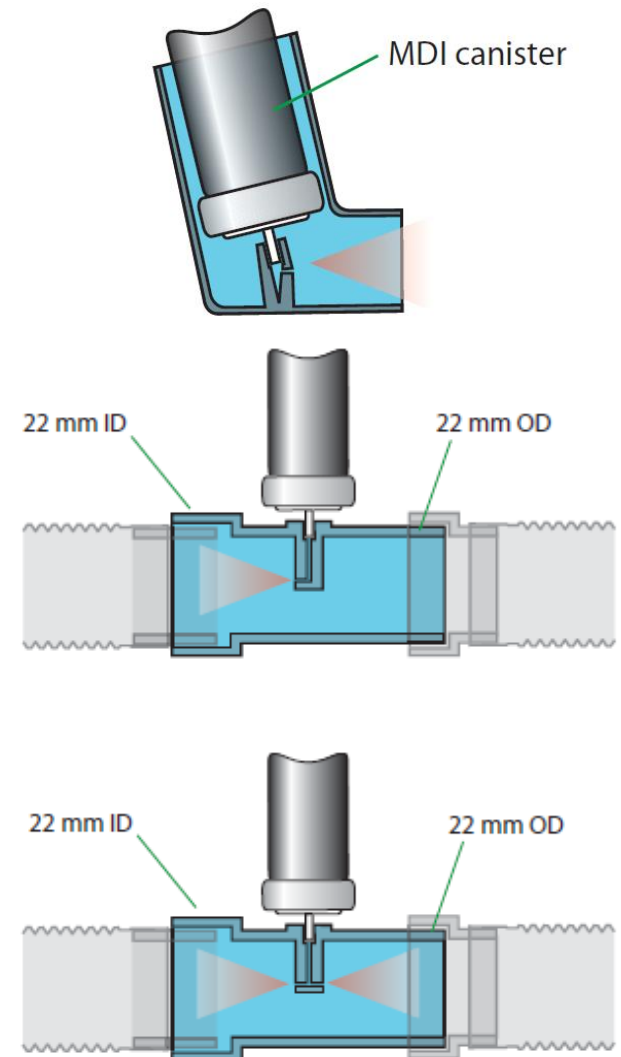

Factors Affecting Aerosol Drug Delivery

Table 4.7 Factors affecting drug delivery via inhalation of aerosol

Ventilator	Fixed Inspiratory flow waveform	Variable Mode, tidal volume, respiratory rate, inspiratory time, triggering mechanism
Breathing circuit delivery system	Tracheal tube size, density of inspired gases	Humidity of inspired gases Type, position in circuit, presence of spacers, timing of delivery
Drug	Particle size, target site, duration of action	Formulation (for some drugs), dose, volume

Commercial Development of Ventilator Technology

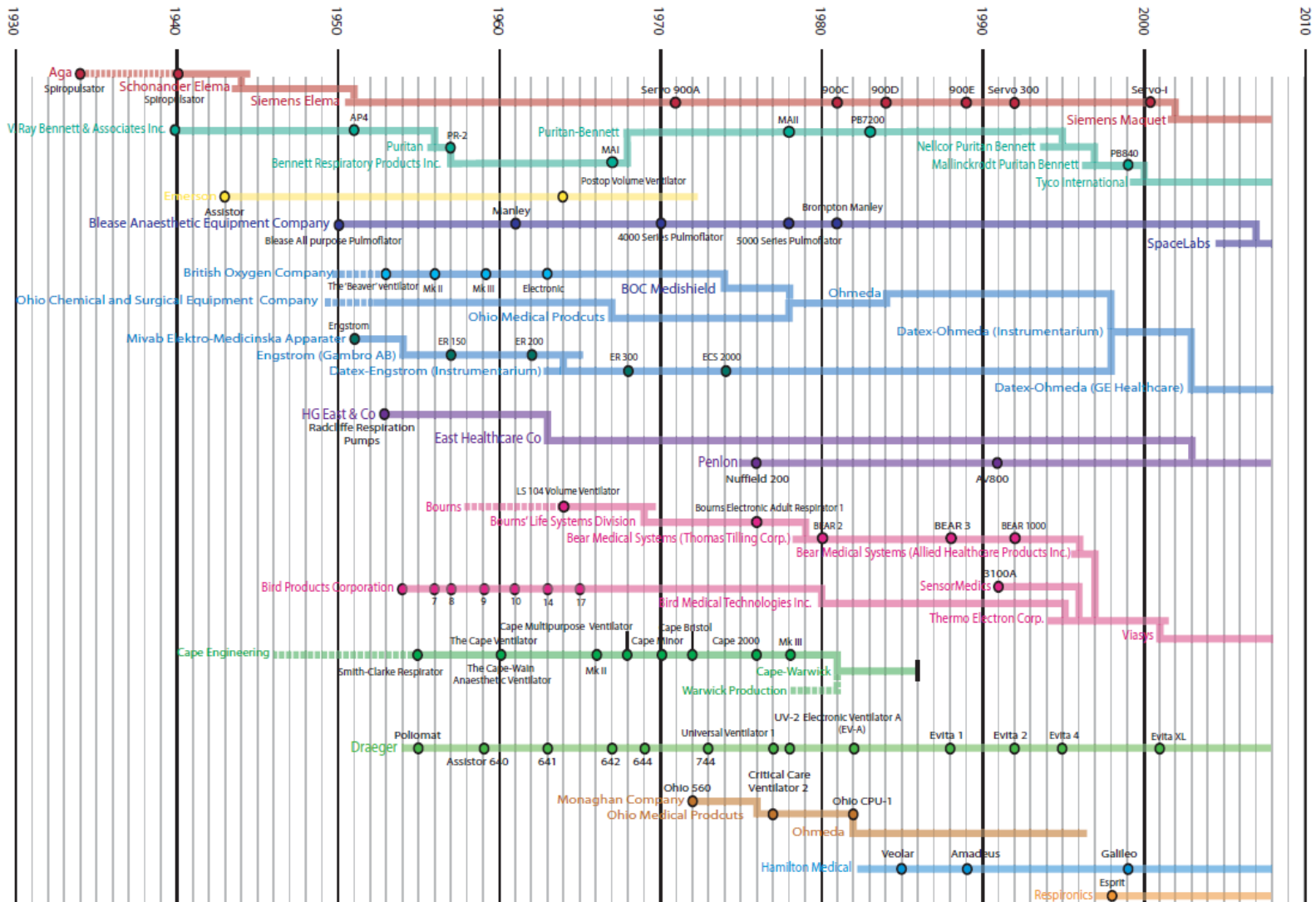

Covered Material

- Parts of chapters 1,3 & 5 of Ventilators handout #1
- Parts of Chapter 5 of Ventilators handout #2