



ELECTRONIC SYSTEM DESIGN

PART 1: ANALOG FILTERS

Prof. Yasser Mostafa Kadah

Why Use Filters?

2

- Detection of a wanted signal may be impossible if unwanted signals and noise are not removed sufficiently by filtering
- Electronic filters allow some signals to pass, but stop others
 - To be more precise, filters allow some signal frequencies applied at their input terminals to pass through to their output terminals with little or no reduction in signal level

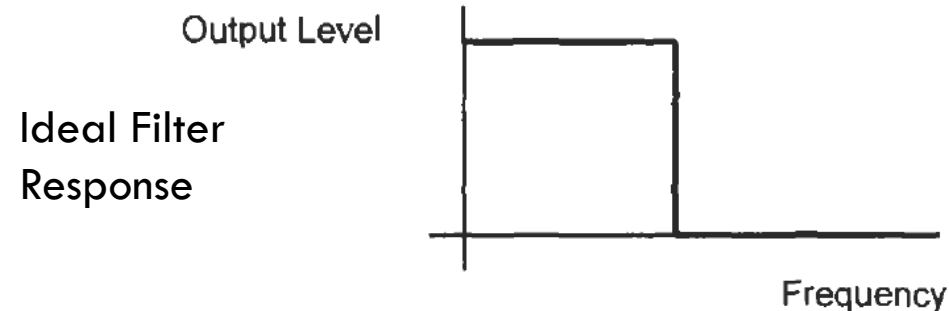

Filter Terminology

3

- **Passband**: Range of signal frequencies that are allowed to pass through a filter, with little or no change to signal level
- **Passband cutoff frequency**: Passband edge where there is a 3 dB reduction in signal amplitude (half-power point)
- **Stopband**: Range of signal frequencies that are reduced in amplitude by an amount specified in the design, and effectively prevented from passing, is called the stopband
- **Transition Zone or Skirt Response**: Range of frequencies in between the passband and the stopband where the reduction in signal amplitude (also known as the attenuation) changes rapidly

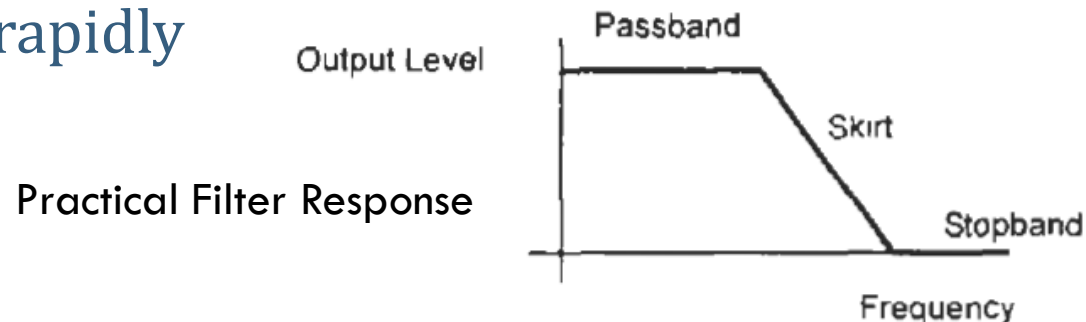

Common Types of Filters

4

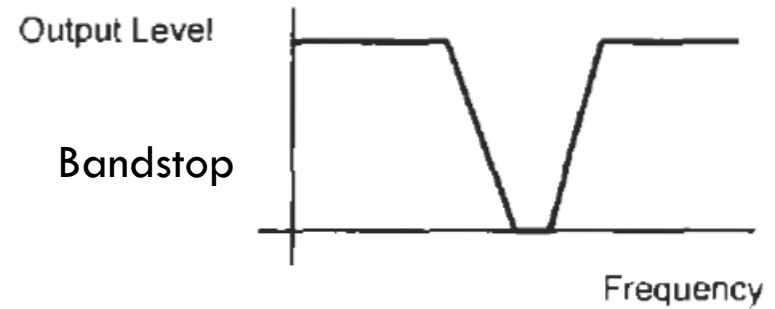
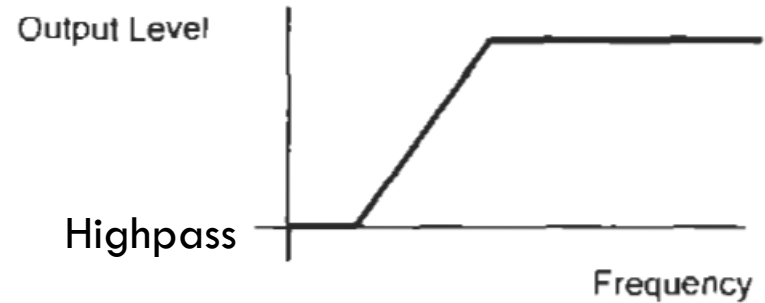
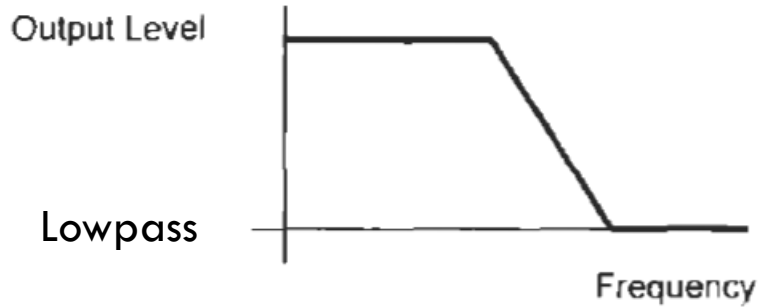

Passband and Stopband Response

5

Output Level

Smooth
Passband

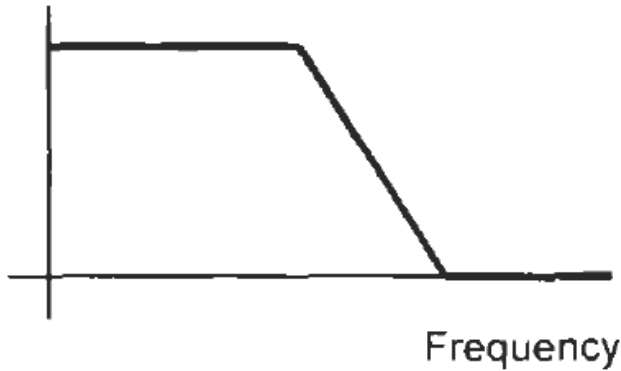

Butterworth or Bessel

Output Level

Passband
Ripple



Chebyshev

Output Level

Stopband
Ripple



Inverse Chebyshev

Output Level

Passband &
Stopband
Ripple

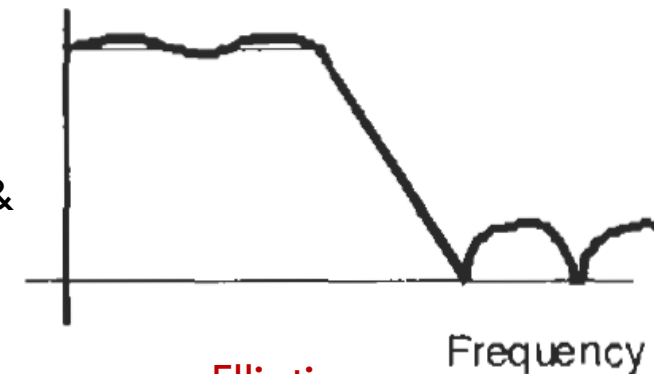

Elliptic

Analog Filter Normalization

6

- A normalized filter is one in which the passband cutoff point is at $\omega = 1$ rad/s
 - ▣ Better than 1 Hz to remove 2π factor in calculations
- Passive filters are normalized for a 1Ω load impedance
- The reason for normalization is to make the calculation of values simple
- Passive analog filters can be designed using the tables of normalized component values
 - ▣ One set of normalized component values can be used to design passive lowpass, highpass, bandpass, and bandstop filters with any load impedance

Design with Normalized Analog Filters

7

- Select the type of response required
- Determine the filter order using the frequency response graphs
- Use normalized analog filter tables to obtain a set of normalized component values
- Scale the obtained normalized component values for the frequency, impedance, and frequency response (lowpass, highpass. etc.) as required

Bessel Response

8

- Bessel response is smooth in the passband, and attenuation rises smoothly in the stopband
 - Stopband attenuation increases very slowly until the signal frequency is several times higher than cutoff point
 - Far away from the cutoff point the attenuation rises at $6n$ dB/octave, where n is the filter order and an octave is the doubling of frequency.
 - For example, a third-order filter will give an 18 dB/octave rise in attenuation

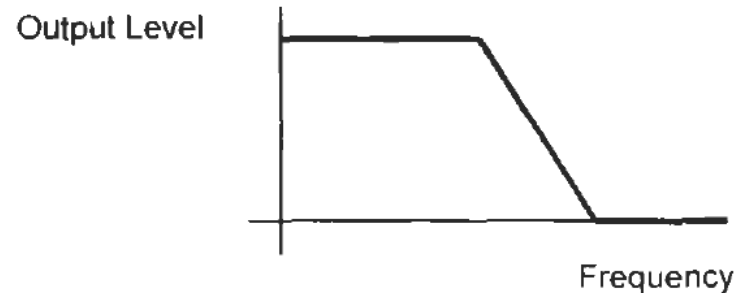

Bessel Response

9

- Natural cutoff frequency for the Bessel response is that which gives a 1 s delay
 - ▣ This is not a constant value, but depends on filter order
- To simplify design, Bessel response can be scaled to give a 3 dB at $\omega=1$ for all filter orders
 - ▣ Scale frequency components of the transfer function

Normalization Factors

$$\sqrt{(2n-1) \cdot \ln 2}$$

Order, n	Normalizing Factor
1	1
2	1.36
3	1.75
4	2.13
5	2.42
6	2.7
7	2.95
8	3.17
9	3.39
10	3.58

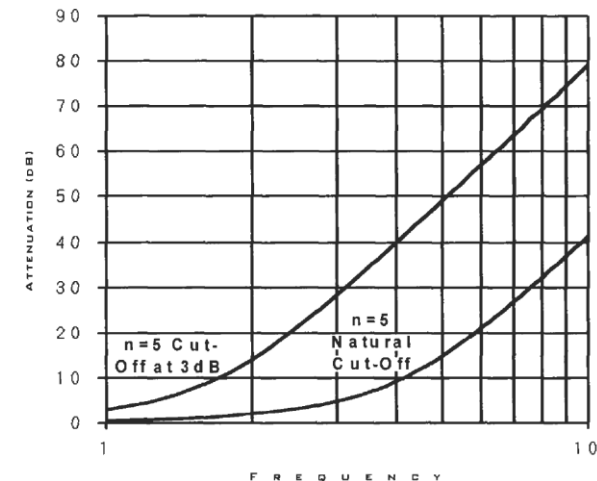

Bessel Response

10

- Attenuation vs. frequency for different order

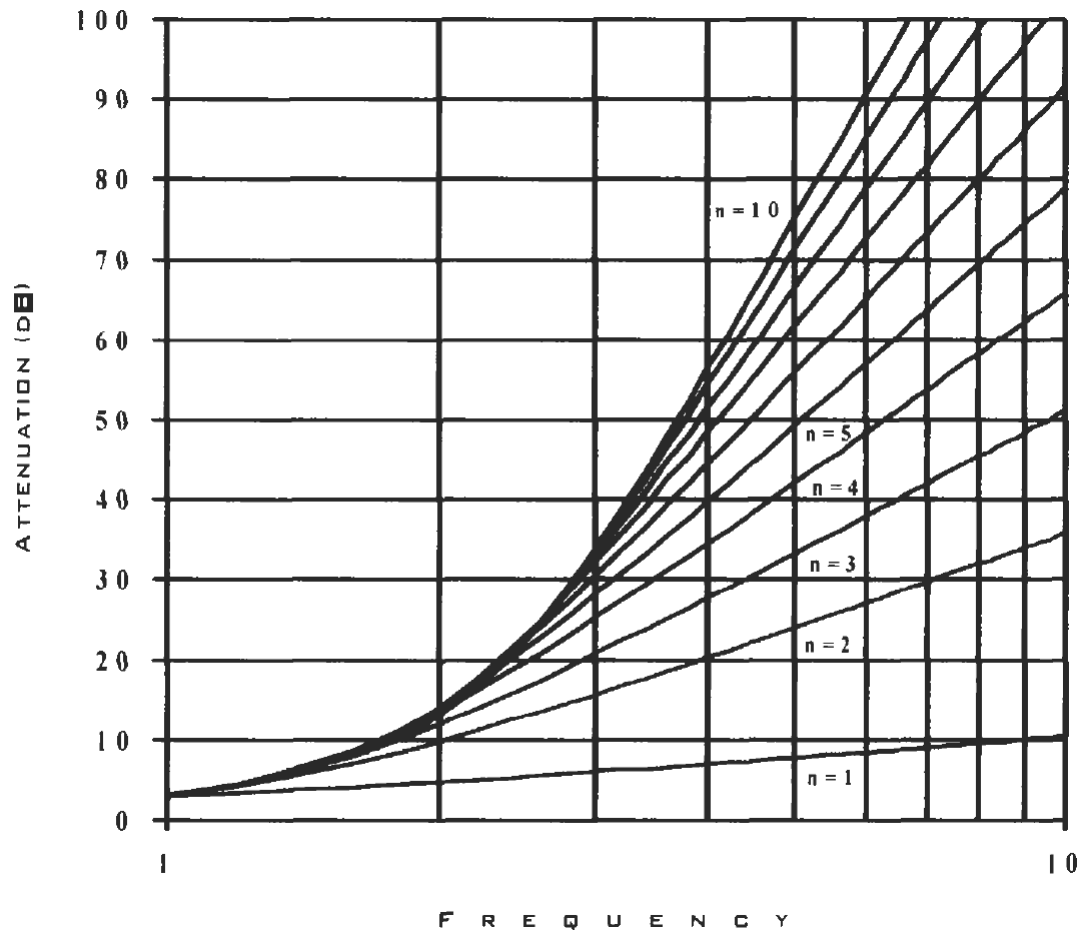

Bessel Normalized Lowpass Filter Component Values

11

- Bessel LC Values $R_s = \infty$ or $R_s = 0$

Order	C1	L2	C3	L4	C5	L6	C7	L8	C9	L10
1	1.0000									
2	1.36	0.4539								
3	1.4631	0.8427	0.2926							
4	1.5012	0.9781	0.6127	0.2114						
5	1.5125	1.0232	0.7531	0.4729	0.1618					
6	1.5124	1.0329	0.8125	0.6072	0.3785	0.1287				
7	1.5087	1.0293	0.8345	0.6752	0.5031	0.3113	0.1054			
8	1.5044	1.0214	0.8392	0.7081	0.5743	0.4253	0.2616	0.0883		
9	1.5006	1.0127	0.8361	0.722	0.6142	0.4963	0.3654	0.2238	0.0754	
10	1.4973	1.0045	0.8297	0.7258	0.6355	0.5401	0.4342	0.3182	0.1942	0.0653
$R_s = 0$	L1'	C2'	L3'	C4'	L5'	C6'	L7'	C8'	L9'	C10'

Bessel Normalized Lowpass Filter Component Values

12

□ Bessel LC Values $R_s = 1$

Order	C1	L2	C3	L4	C5	L6	C7	L8	C9	L10
1	2.000									
2	0.576	2.148								
3	0.3374	0.9705	2.2034							
4	0.2334	0.6725	1.0815	2.2404						
5	0.1743	0.5072	0.804	1.111	2.2582					
6	0.1365	0.4002	0.6392	0.8538	1.1126	2.2645				
7	0.1106	0.3259	0.5249	0.702	0.869	1.1052	2.2659			
8	0.0919	0.2719	0.4409	0.5936	0.7303	0.8695	1.0956	2.2656		
9	0.078	0.2313	0.377	0.5108	0.6306	0.7407	0.8639	1.0863	2.2649	
10	0.0672	0.1998	0.327	0.4454	0.5528	0.6493	0.742	0.8561	1.0781	2.2641
$R_s = 1$	L1'	C2'	L3'	C4'	L5'	C6'	L7'	C8'	L9'	C10'

Bessel Normalized Lowpass Filter Component Values

13

□ Bessel LC Values $R_s = 2$

Order	C1	L2	C3	L4	C5	L6	C7	L8	C9	L10
1	1.5000									
2	0.2601	3.5649								
3	1.8572	0.9174	0.3176							
4	0.112	1.2952	0.5202	3.7824						
5	1.90385	1.0764	0.7836	0.493	0.169					
6	0.0666	0.7824	0.3131	1.6752	0.5405	3.8122				
7	1.9045	1.0748	0.8555	0.6914	0.51605	0.3198	0.1084			
8	0.0452	0.5354	0.2173	1.1718	0.3608	1.7153	0.5329	3.8041		
9	1.8996	1.0566	0.8530	0.7334	0.62415	0.505	0.37225	0.2282	0.0769	
10	0.0332	0.3951	0.1617	0.8818	0.2739	1.2879	0.3678	1.6913	0.5242	3.7953
$R_s = \frac{1}{2}$	L1'	C2'	L3'	C4'	L5'	C6'	L7'	C8'	L9'	C10'

Bessel Response Filter Examples

14

□ Fifth-Order Lowpass $R_s \geq 1$

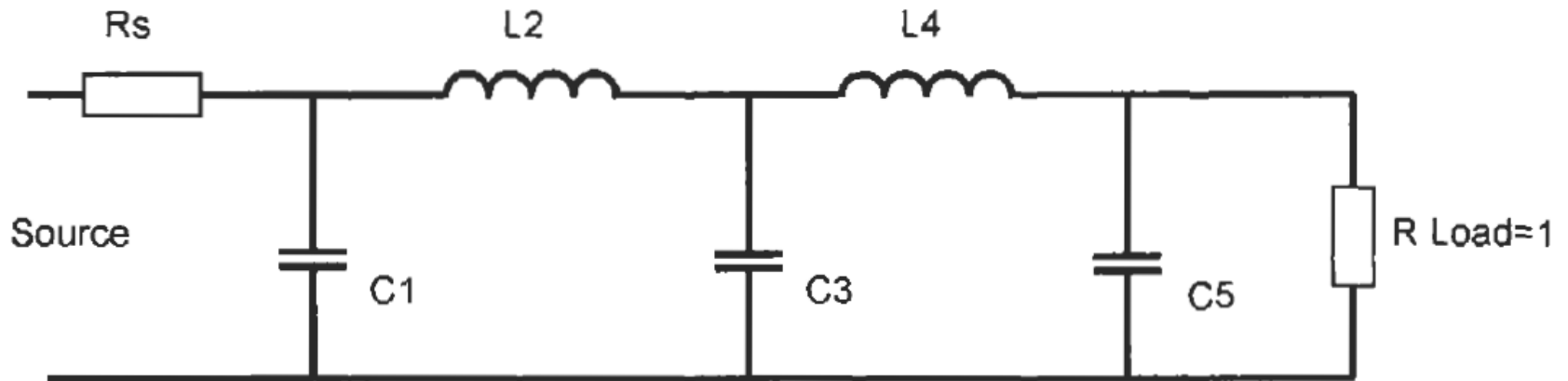

□ Fifth-Order Lowpass $R_s \leq 1$

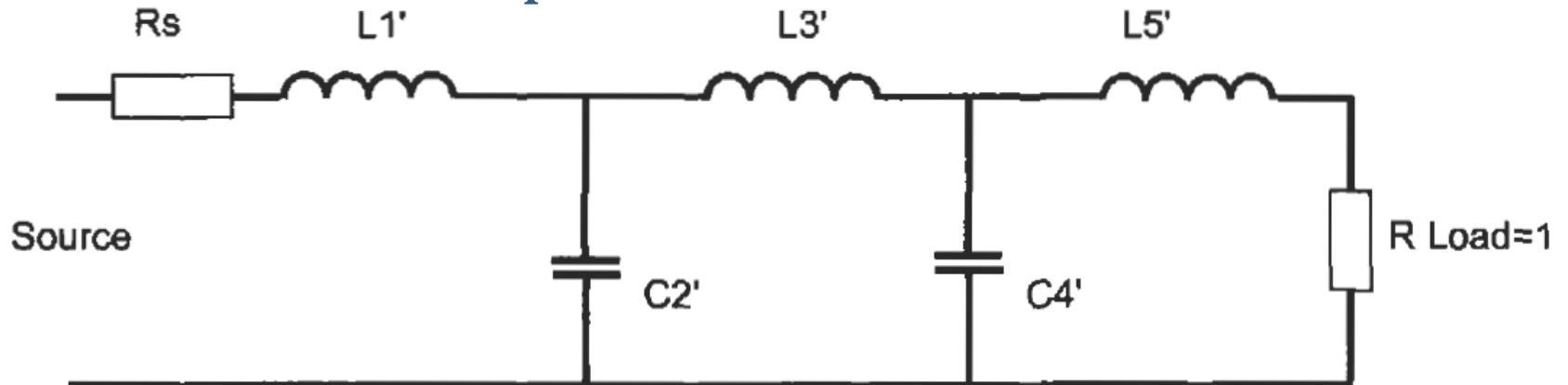

Bessel Response Filter Examples

15

□ Sixth-Order Lowpass $R_s \geq 1$

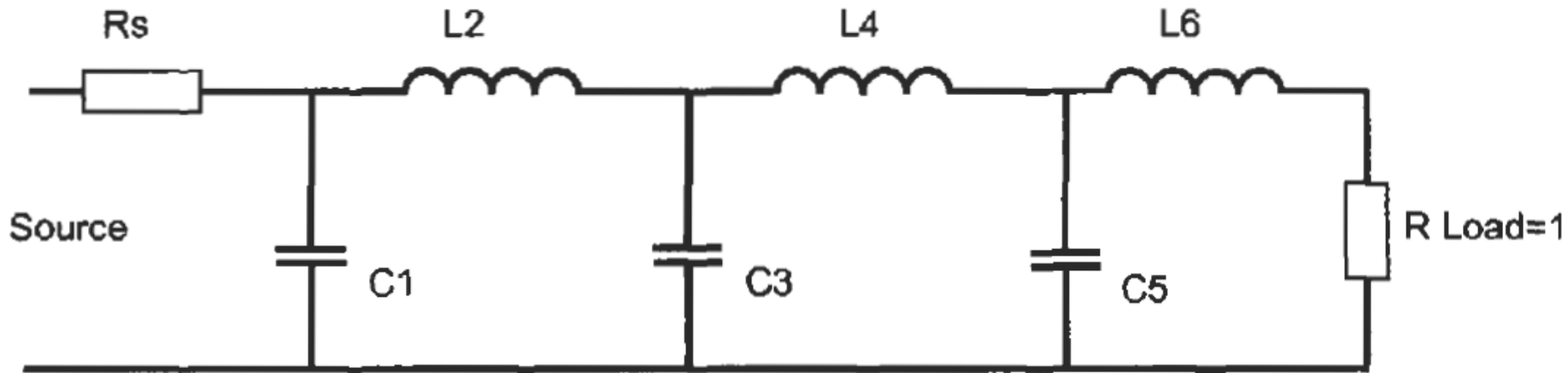

□ Sixth-Order Lowpass $R_s \leq 1$

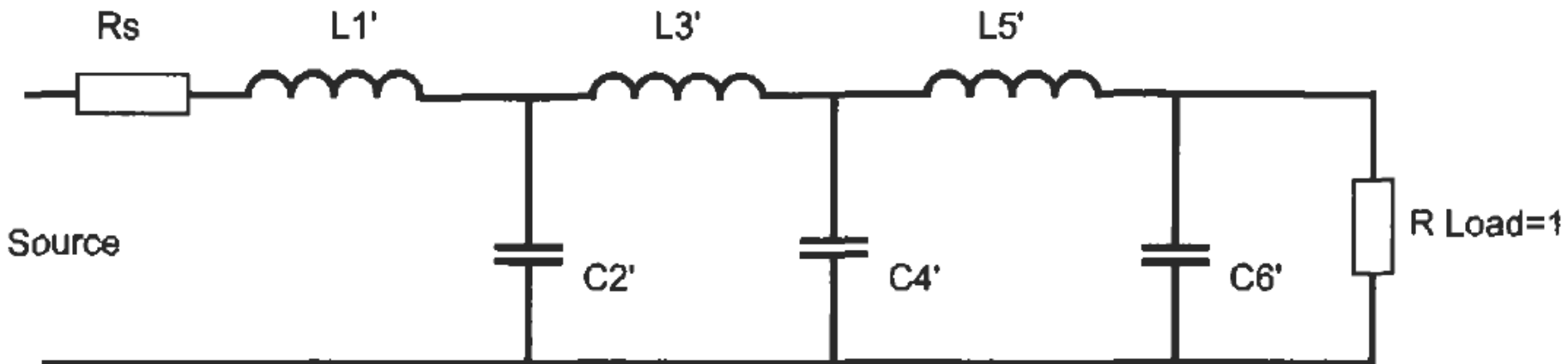

Butterworth Response

16

- Butterworth response has a smooth passband and a smooth increase in stopband attenuation.
 - It differs from Bessel response in that the attenuation in the stopband rises by $6n$ dB/octave almost immediately outside the passband

Example: For 60dB attenuation at 3x cutoff Frequency, the $\omega=3$ axis and 60dB attenuation axis cross at a point midway between the curves of $n = 6$ and $n = 7$. Choose order=7.

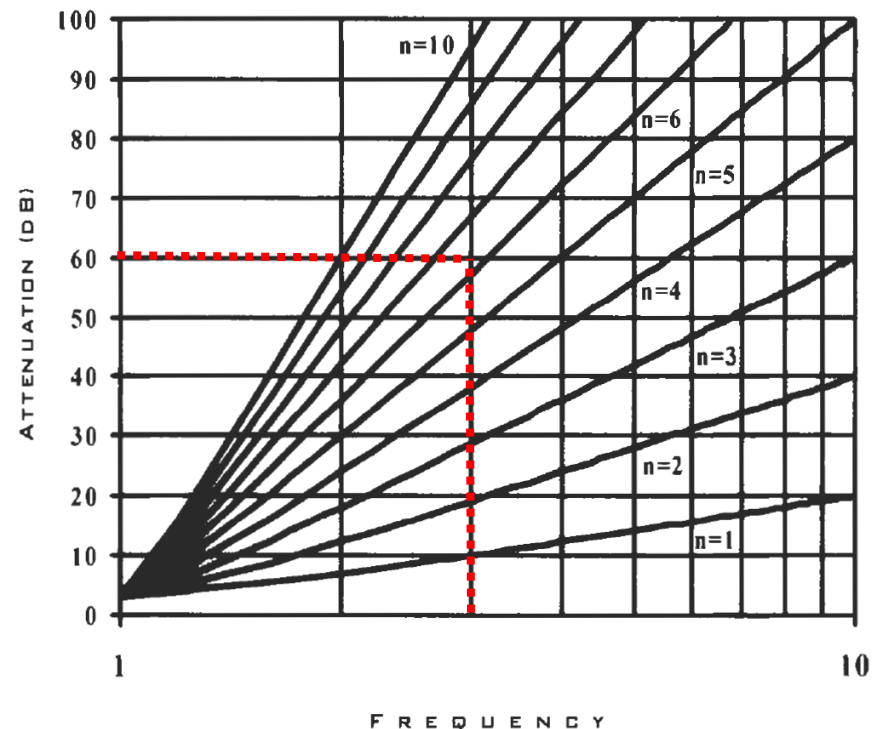
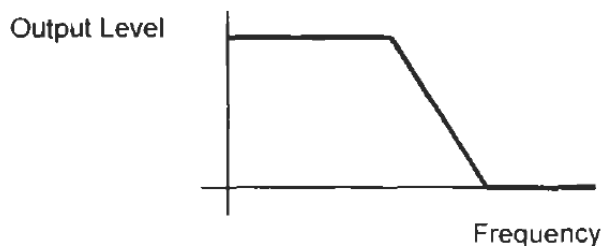

Butterworth Response

17

- Butterworth passive lowpass filters have a ladder network of series inductors with shunt capacitors at their connection nodes
 - First component in this ladder can be either a series inductor or a shunt capacitor

First Component is Shunt C

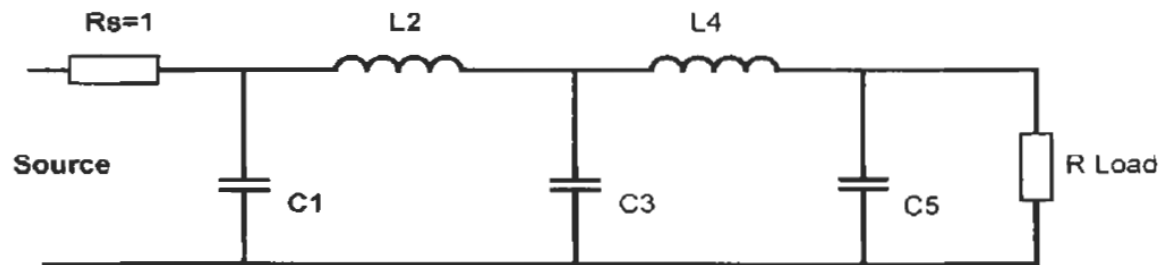

First Component is Series L

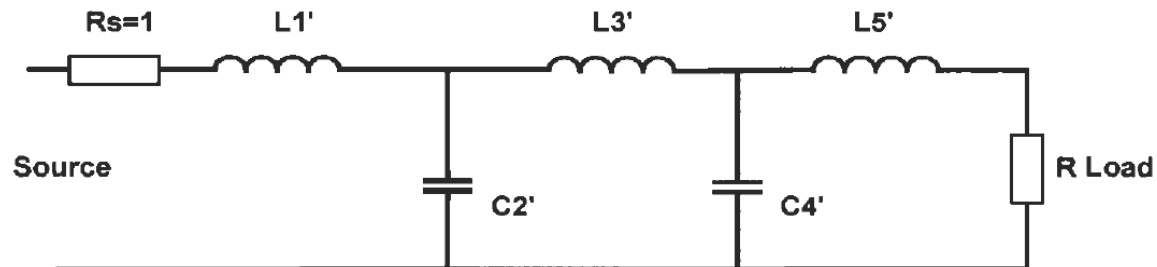

Butterworth Normalized Lowpass Component Values

18

- Butterworth LC Values $R_s = \infty$ or $R_s = 0$

Order	C1	L2	C3	L4	C5	L6	C7	L8	C9	L10
1	1.00000									
2	1.41422	0.70711								
3	1.50000	1.33333	0.50000							
4	1.53074	1.57716	1.08239	0.38268						
5	1.54509	1.69443	1.38196	0.89443	0.30902					
6	1.55292	1.75931	1.55291	1.20163	0.75787	0.25882				
7	1.55765	1.79883	1.65883	1.39717	1.05496	0.65597	0.22521			
8	1.56073	1.82464	1.72874	1.52832	1.25882	0.93705	0.57755	0.19509		
9	1.56284	1.84241	1.77719	1.62019	1.40373	1.14076	0.84136	0.51555	0.17365	
10	1.56435	1.85516	1.81211	1.68689	1.51000	1.29209	1.04062	0.76263	0.46538	0.15643
$R_s = 0$	L1'	C2'	L3'	C4'	L5'	C6'	L7'	C8'	L9'	C10'

Butterworth Normalized Lowpass Component Values

19

□ Butterworth LC Values $R_s = 1$

Order	C1	L2	C3	L4	C5	L6	C7	L8	C9	L10
1	2.0000									
2	1.41421	1.41421								
3	1.00000	2.00000	1.00000							
4	0.76537	1.84776	1.84776	0.76537						
5	0.61803	1.61803	2.00000	1.61803	0.61803					
6	0.51764	1.41421	1.93185	1.93185	1.41421	0.51764				
7	0.44504	1.24698	1.80194	2.00000	1.80194	1.24698	0.44504			
8	0.39018	1.11114	1.66294	1.96157	1.96157	1.66294	1.11114	0.39018		
9	0.34730	1.00000	1.53209	1.87938	2.00000	1.87938	1.53209	1.00000	0.34730	
10	0.31287	0.90798	1.41421	1.78201	1.97538	1.97538	1.78201	1.41421	0.90798	0.31287
	L1'	C2'	L3'	C4'	L5'	C6'	L7'	C8'	L9'	C10'

Chebyshev Response

20

- Chebyshev response has ripples in the passband but a smooth increase in stopband attenuation.
 - ▣ By allowing the passband response to have ripples, the stopband attenuation rises sharply just beyond the cutoff frequency.
- Further beyond the cutoff frequency, the attenuation rises by $6n$ dB/octave, which is the same as the Butterworth.
 - ▣ However, for a filter of equal order measured at the same frequency, a Chebyshev response will produce more stopband attenuation because of the sudden rise in attenuation immediately beyond the cutoff point.
- Graphs are for different passband ripples

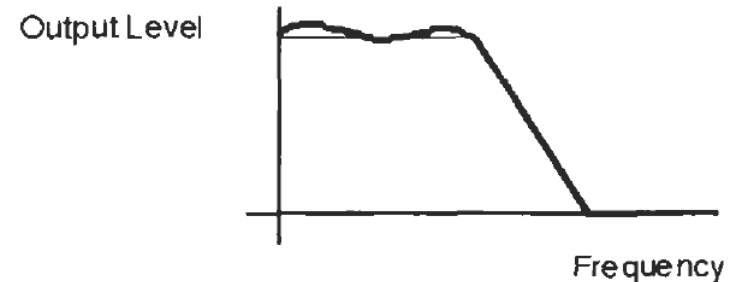

Chebyshev Response

21

0.01 dB Ripple

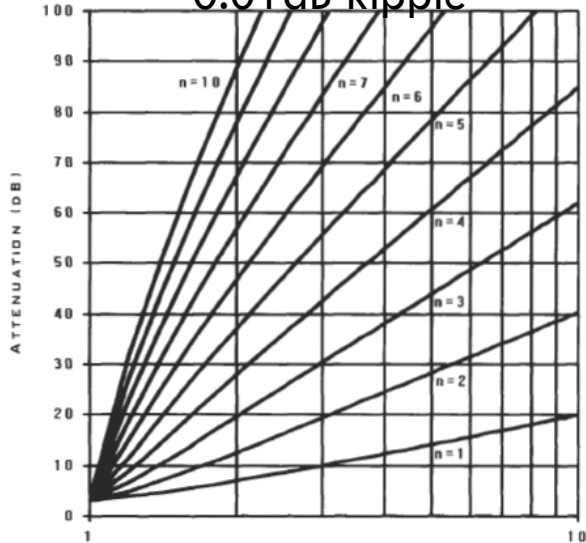

0.1 dB Ripple

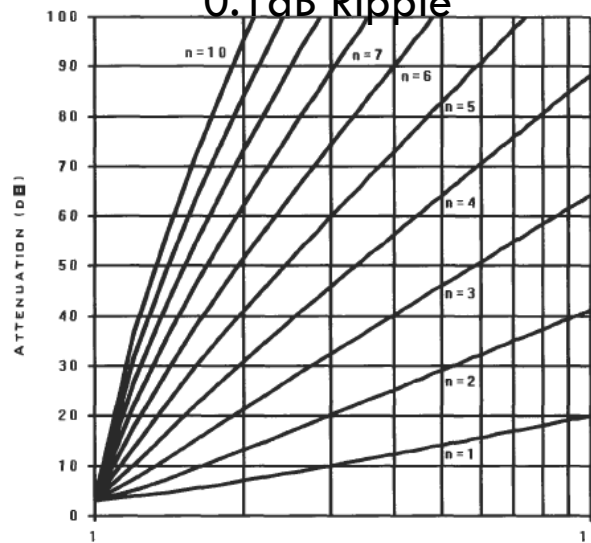

0.25 dB Ripple

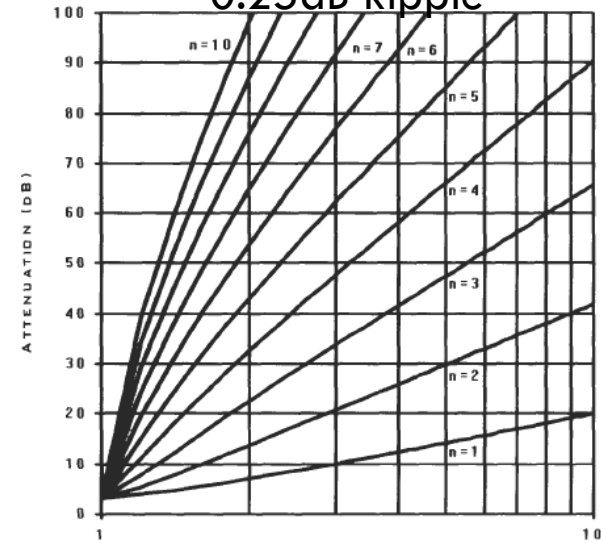

0.5 dB Ripple

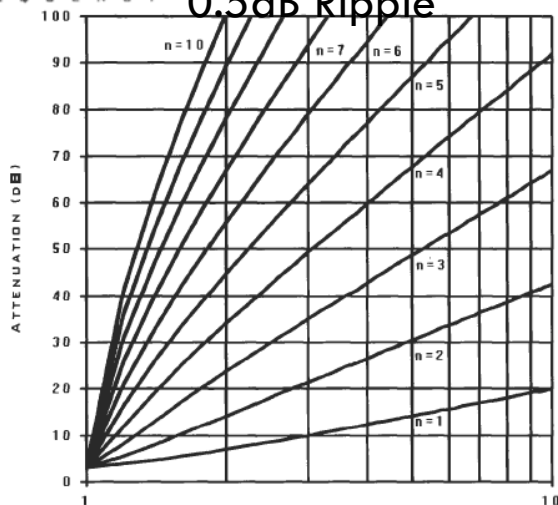

1 dB Ripple

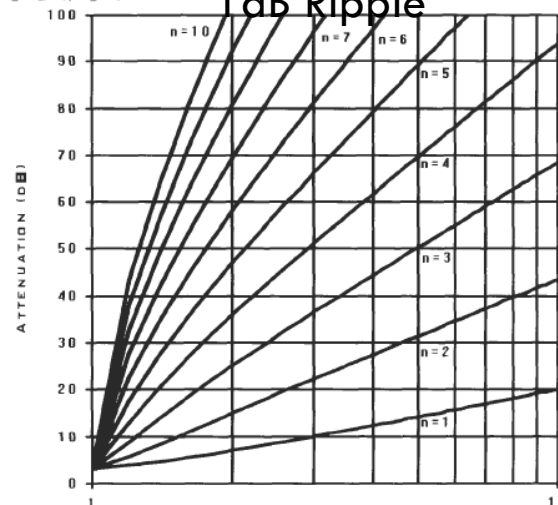

FREQUENCY

FREQUENCY

Chebyshev Tables: Equal Source and Load Impedances

Order	C1	L2	C3	L4	C5	L6	C7	L8	C9
3	1.18111	1.82142	1.18111						
5	0.97660	1.68494	2.03666	1.68494	0.97660				
7	0.91273	1.59470	2.00209	1.87037	2.00209	1.59470	0.91273		
9	0.88538	1.55131	1.96146	1.86164	2.07173	1.86164	1.96146	1.55131	0.88538
	L1'	C2'	L3'	C4'	L5'	C6'	L7'	C8'	L9'

Table 2.10

Normalized Chebyshev Element Values, 0.01dB Ripple

Order	C1	L2	C3	L4	C5	L6	C7	L8	C9
3	1.43286	1.59373	1.43286						
5	1.30134	1.55594	2.24110	1.55594	1.30134				
7	1.26152	1.51955	2.23927	1.68038	2.23927	1.51955	1.26152		
9	1.24466	1.50168	2.22199	1.68293	2.29571	1.68293	2.22199	1.50168	1.24466
	L1'	C2'	L3'	C4'	L5'	C6'	L7'	C8'	L9'

Table 2.11

Normalized Chebyshev Element Values, 0.1dB Ripple

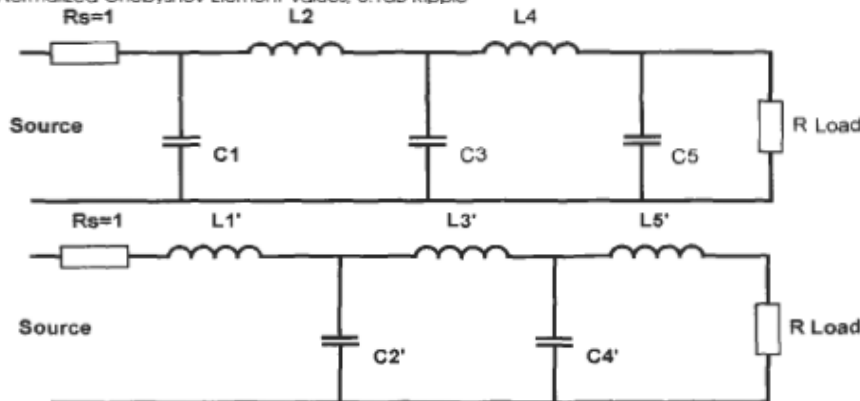

Order	C1	L2	C3	L4	C5	L6	C7	L8	C9
3	1.63306	1.43616	1.63306						
5	1.53996	1.43493	2.44027	1.43493	1.53996				
7	1.51189	1.41692	2.45311	1.53492	2.45311	1.41692	1.51189		
9	1.50000	1.40755	2.44460	1.54062	2.50767	1.54062	2.44460	1.40755	1.50000
	L1'	C2'	L3'	C4'	L5'	C6'	L7'	C8'	L9'

Table 2.12

Normalized Chebyshev Element Values, 0.25 dB Ripple

Order	C1	L2	C3	L4	C5	L6	C7	L8	C9
3	1.86369	1.28036	1.86369						
5	1.80691	1.30248	2.69145	1.30248	1.80691				
7	1.78962	1.29608	2.71773	1.38476	2.71773	1.29608	1.78962		
9	1.78229	1.29208	2.71630	1.39214	2.77344	1.39214	2.71630	1.29208	1.78229
	L1'	C2'	L3'	C4'	L5'	C6'	L7'	C8'	L9'

Table 2.13

Normalized Chebyshev Element Values, 0.5 dB Ripple

Order	C1	L2	C3	L4	C5	L6	C7	L8	C9
3	2.21565	1.08839	2.21565						
5	2.20715	1.12798	3.10248	1.12798	2.20715				
7	2.20391	1.13061	3.14695	1.19368	3.14695	1.13061	2.20391		
9	2.20246	1.13079	3.15397	1.20201	3.20772	1.20201	3.15397	1.13079	2.20246
	L1'	C2'	L3'	C4'	L5'	C6'	L7'	C8'	L9'

Table 2.14

Normalized Chebyshev Element Values, 1 dB Ripple

Chebyshev Tables: Zero or Infinite Source Impedances

Order	C1	L2	C3	L4	C5	L6	C7	L8	C9	L10
1	1.00000									
2	1.41336	0.74228								
3	1.50124	1.43296	0.59054							
4	1.52930	1.69459	1.31270	0.52307						
5	1.54664	1.79501	1.64491	1.23650	0.48829					
6	1.55130	1.84753	1.79009	1.59789	1.19066	0.46868				
7	1.55932	1.86709	1.86566	1.76514	1.56334	1.16096	0.45636			
8	1.55903	1.88502	1.89902	1.85578	1.74349	1.53932	1.14133	0.44834		
9	1.56456	1.88838	1.92421	1.89768	1.84251	1.72607	1.52167	1.12734	0.44269	
10	1.56262	1.89792	1.93251	1.92894	1.89081	1.83103	1.71295	1.50890	1.11738	0.43868
Rs = 0	L1'	C2'	L3'	C4'	L5'	C6'	L7'	C8'	L9'	C10'

Table 2.16
Normalized 0.01dB Chebyshev Element Values, Rs = ∞ or 0

Order	C1	L2	C3	L4	C5	L6	C7	L8	C9	L10
1	1.00000									
2	1.40488	0.82725								
3	1.51328	1.50900	0.71642							
4	1.51567	1.77396	1.45978	0.67474						
5	1.56126	1.80689	1.76588	1.41728	0.65065					
6	1.53633	1.88669	1.83342	1.75125	1.39590	0.63933				
7	1.57477	1.85775	1.92103	1.82699	1.73396	1.37856	0.63075			
8	1.54355	1.91231	1.90251	1.92697	1.82167	1.72463	1.36955	0.62633		
9	1.58037	1.87275	1.95841	1.90942	1.92294	1.81361	1.71504	1.36113	0.62232	
10	1.54689	1.92121	1.92274	1.97115	1.91128	1.92054	1.80936	1.71000	1.35669	0.62020
Rs = 0	L1'	C2'	L3'	C4'	L5'	C6'	L7'	C8'	L9'	C10'

Table 2.17
Normalized 0.1dB Chebyshev Element Values, Rs = ∞ or 0

Order	C1	L2	C3	L4	C5	L6	C7	L8	C9	L10
1	1.00000									
2	1.38934	0.90986								
3	1.53459	1.52828	0.81651							
4	1.49240	1.83405	1.51681	0.79093						
5	1.58646	1.78565	1.83856	1.48558	0.76996					
6	1.51127	1.92783	1.82548	1.83907	1.47670	0.76375				
7	1.60115	1.82834	1.96618	1.82342	1.82607	1.46285	0.75593			
8	1.51783	1.94883	1.87811	1.97925	1.82513	1.82364	1.45940	0.75382		
9	1.60726	1.84134	1.99659	1.88630	1.97701	1.81910	1.81573	1.45231	0.75000	
10	1.52086	1.95624	1.89342	2.01317	1.89184	1.97865	1.81878	1.81444	1.45086	0.74915
Rs = 0	L1'	C2'	L3'	C4'	L5'	C6'	L7'	C8'	L9'	C10'

Table 2.18
Normalized 0.25 dB Chebyshev Element Values, Rs = ∞ or 0

Order	C1	L2	C3	L4	C5	L6	C7	L8	C9	L10
1	1.00000									
2	1.36144	1.01565								
3	1.57200	1.51790	0.93182							
4	1.45345	1.91162	1.53954	0.92395						
5	1.62994	1.73996	1.92168	1.51377	0.90343					
6	1.46994	1.99084	1.79019	1.93593	1.51606	0.90305				
7	1.64643	1.77716	2.03065	1.78918	1.92388	1.50337	0.89478			
8	1.47565	2.00848	1.83056	2.05041	1.79671	1.92786	1.50504	0.89433		
9	1.65329	1.78899	2.05701	1.83833	2.04815	1.79101	1.91988	1.49810	0.89112	
10	1.47828	2.01478	1.84229	2.07746	1.84692	2.05357	1.79404	1.92217	1.49949	0.89185
Rs = 0	L1'	C2'	L3'	C4'	L5'	C6'	L7'	C8'	L9'	C10'

Table 2.19
Normalized 0.5 dB Chebyshev Element Values, Rs = ∞ or 0

Order	C1	L2	C3	L4	C5	L6	C7	L8	C9	L10
1	1.00000									
2	1.30223	1.19145								
3	1.65199	1.45972	1.10778							
4	1.37686	2.05105	1.51740	1.12742						
5	1.72155	1.64455	2.06119	1.49297	1.10354					
6	1.38984	2.11627	1.70474	2.09336	1.50789	1.11259				
7	1.74142	1.67712	2.15585	1.70229	2.07901	1.49453	1.10192			
8	1.39431	2.13071	1.73338	2.18479	1.71600	2.09151	1.50218	1.10717		
9	1.74970	1.68810	2.17984	1.73916	2.18069	1.70937	2.08153	1.49435	1.10119	
10	1.39636	2.13592	1.74170	2.20597	1.75099	2.19124	1.71609	2.08873	1.49916	1.10462
Rs = 0	L1'	C2'	L3'	C4'	L5'	C6'	L7'	C8'	L9'	C10'

Table 2.20
Normalized 1dB Chebyshev Element Values, Rs = ∞ or 0

Formulae for Passive Lowpass Filter Denormalization

24

- In practice, the design would be scaled for impedance and frequency in one step, by substitution of values into the given formulae:

$$L = \frac{RL^*}{2\pi F_c}$$

$$C = \frac{C^*}{2\pi F_c R}$$

- L^* and C^* are the normalized lowpass component values, while L and C are the final values after scaling

Analog Filter Design Example

25

- Design a fourth-order lowpass filter with 600Ω load impedance and a cutoff frequency of 3.4kHz for telephone band speech. The filter is to be driven from a 0Ω source (an ideal op-amp) and a 0.1 dB ripple Chebyshev response
 - From tables, normalized component values are $L1' = 1.51567$; $C2' = 1.77396$; $L3' = 1.45978$; $C4' = 0.67474$.
 - The apostrophe indicates that ladder network begins with a series inductor
 - Scaled component values for this filter are: $L1 = 42.57\text{mH}$; $C2 = 138.4\text{nF}$; $L3 = 41.0\text{mH}$; $C4 = 52.64\text{nF}$.

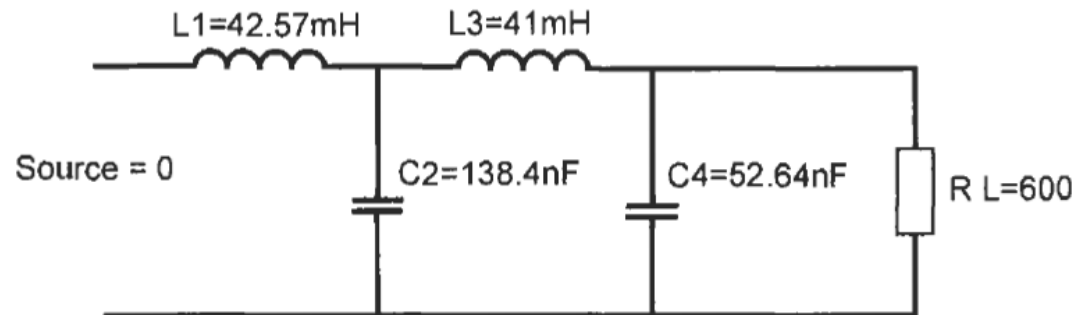

Assignments

26

- Design a 5th order Butterworth low pass filter with $1\text{k}\Omega$ load impedance and a cutoff frequency of 10 kHz for telephone band speech. The filter is to be driven from a 0Ω source (an ideal op-amp).
- Repeat the above problem for a Bessel filter.