

MEDICAL EQUIPMENT II - 2011

HEMODIALYSIS

Hemodialysis Machines

- Single-patient hemodialysis machines deliver a patient's dialysis prescription by controlling blood and dialysate flows through the dialyzer.
 - ▣ Removal of waste metabolites
 - ▣ Removal of water
- Hemodialysis machines incorporate monitoring and alarm systems that protect the patient against adverse events that may arise from equipment malfunction during the dialysis treatment.

Hemodialysis System Components

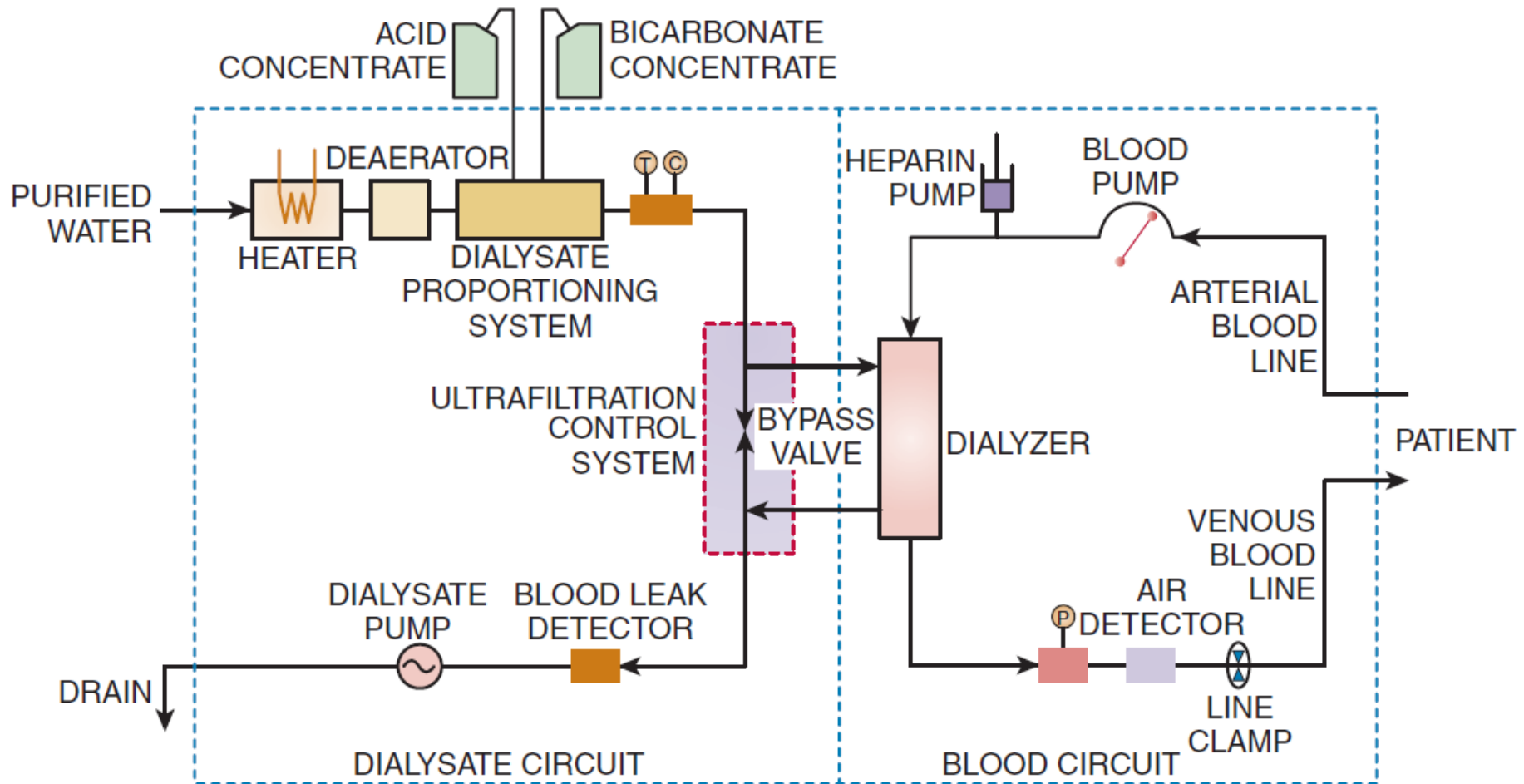

(C = conductivity monitor, P = pressure monitor, T = temperature monitor)

Extracorporeal Blood Circuit

- Consists of an access device (needles or catheter), blood tubing, blood pump, and dialyzer.
 - ▣ Includes a pump for continuous administration of heparin during dialysis.
- Role of the blood circuit is to deliver blood to the dialyzer at the prescribed flow rate and then return the blood to the patient.
 - ▣ This goal must be achieved without damaging blood components and without loss of circuit integrity that may lead to blood loss or the entry of air or other harmful substances, such as bacteria, into the blood.
- Urea clearance depends in large part on effective blood flow rate through extracorporeal circuit.
 - ▣ Established using a roller pump (also known as a rotary peristaltic pump) that allows flows in the range of 50 to 600 mL/min.
 - ▣ Blood flow rate setting on the pump is based on the speed of the pump (revolutions/minute) and the volume of pump segment of blood tubing set.

Dialysate Circuit

- Principal functions of the dialysate circuit:
 - ▣ To prepare dialysate from concentrate and water
 - ▣ To deliver it to the dialyzer at the prescribed temperature (generally 35–37°C) and flow rate
 - ▣ To control fluid removal from the patient
- Dialysate is prepared by the addition of electrolyte concentrate to warmed and deaerated water.
 - ▣ two separate concentrates must be used to prepare dialysate
 - ▣ Bicarbonate concentrate contains sodium bicarbonate, and in some cases some sodium chloride.
 - ▣ Acid concentrate contains all remaining dialysate constituents, a small amount of acid needed to buffer bicarbonate in final dialysate

Dialysate proportioning systems

- System A: Fixed-volume proportioning of water, acid concentrate, and bicarbonate concentrate.
- System B: Dynamic proportioning using conductivity measurement to control the acid and bicarbonate concentrate pumps.
- System C: Dynamic proportioning using a powder cartridge to prepare the bicarbonate concentrate online

A = acid concentrate

B = bicarbonate concentrate

CM = conductivity monitor

CS = conductivity set point

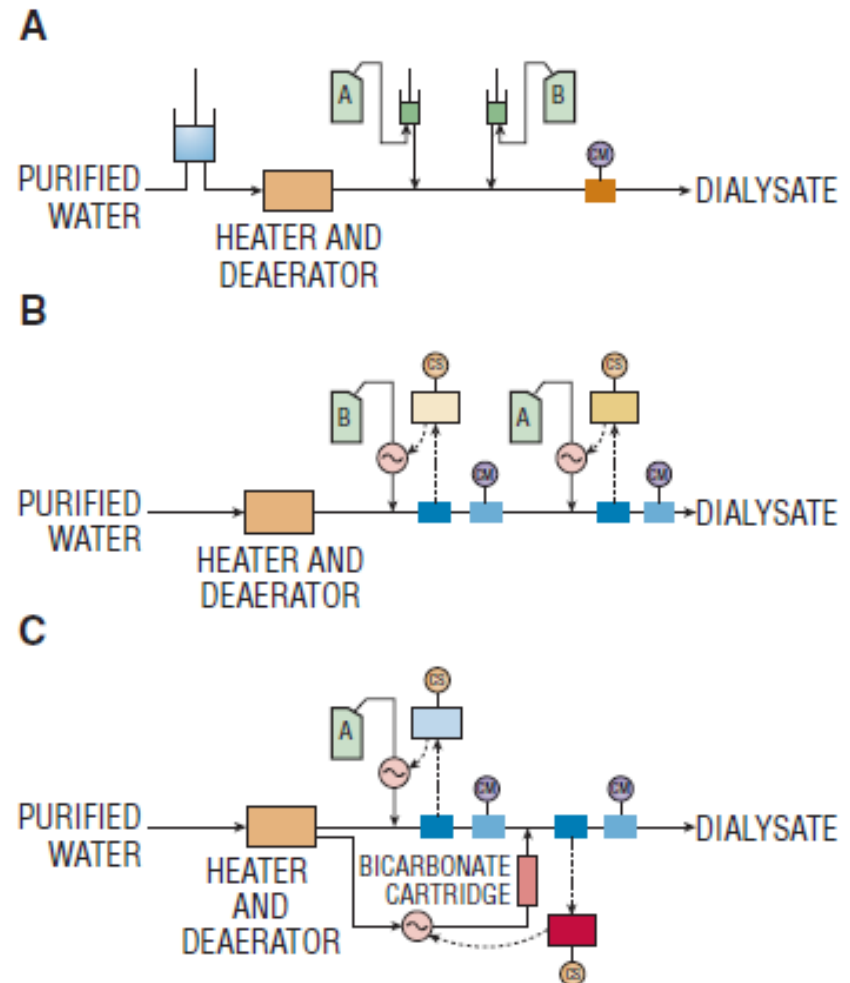

Dialysate proportioning systems

- Several ratios of concentrate to water in common use depending on system
 - ▣ 1:1.225:32.775, 1:1.83:34, and 1:1.72:42.28 (acid conc: bicarbonate conc: water).
 - ▣ Each proportioning ratio requires its own particular acid and bicarbonate concentrates.
- Some machines are designed for use with a single proportioning ratio, whereas other machines can be set to use different proportioning ratios.
- Because machines monitor dialysate composition based on conductivity, use of the wrong concentrates can lead to dialysate of the correct conductivity but the wrong composition.
 - ▣ Therefore, failure to use the correct machine setting or to use the correct concentrates with a given machine can lead to patient injury.

Fluid Removal: Ultrafiltration

- Older systems: no direct control
 - ▣ Tricky and depends on dialyser properties and control of pressures
 - ▣ error leads to excess water removal
- Current systems: volumetric control
- System A: Flow sensor-based system
- System B: Balancing chamber system
 - ▣ Left side of the balancing chamber meters fresh dialysate and the right side meters spent dialysate
- Flow sensors limit dialysate flow rate
 - ▣ No limitation with balancing chamber

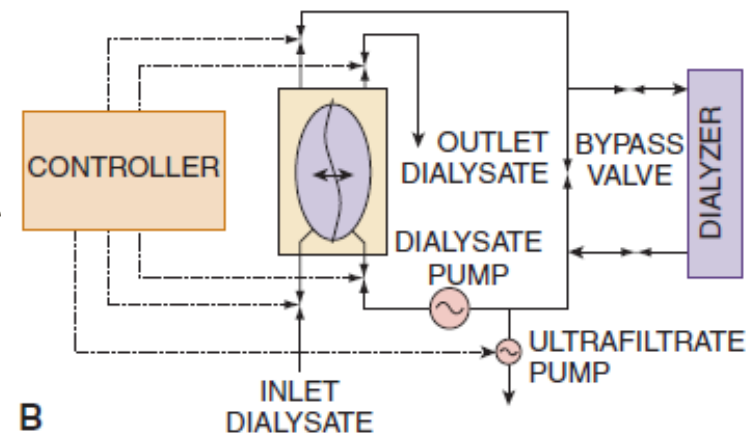
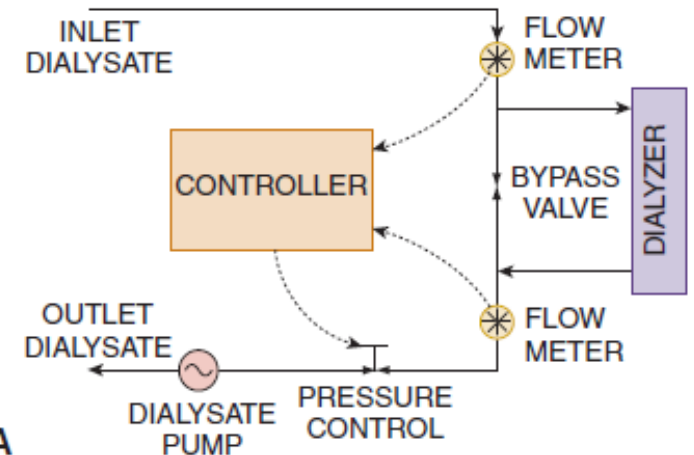

Cleaning and Disinfection

- Hemodialysis machines must be cleaned and disinfected regularly to prevent buildup of chemical and bacterial deposits in the dialysate flow path
 - ▣ Such deposits can interfere with conductivity-based monitoring systems and flow-meter–based ultrafiltration control systems
- To prevent the chemical buildup of carbonate deposits, machines are rinsed with acetic acid (vinegar) or citric acid
- To prevent bacterial buildup, machines must be disinfected at least daily with a chemical disinfectant such as sodium hypochlorite (bleach)
 - ▣ Some machines also incorporate a hot water disinfection cycle

Monitoring and Control

Required Safety-Monitoring Systems for Single-Patient Hemodialysis Machines

Monitor	Location	Alarm Condition	Protects Against
Pressure	Venous blood line	Blood line separation or occlusion	Blood loss
Air bubble or foam	Venous blood line	Pre-pump line separation	Air embolus
Temperature	Dialysate	Temperature outside preset range	Hemolysis (>42°C), energy loss (<35°C)
Conductivity	Dialysate	Conductivity outside preset range	Hypo- or hyperosmolar dialysate, low- or high-bicarbonate dialysate
Hemoglobin	Dialysate	Dialyzer membrane rupture	Blood loss

Monitoring and Control

Optional Automated Therapy Monitoring and Control Systems for Single-Patient Hemodialysis Machines

Monitored Variable

Machine parameters (flow rates, pressures, treatment time, ultrafiltration rate, etc.)

Blood pressure (oscillometric method)

Conductivity clearance (dialysate)

Hematocrit or plasma protein concentration

Thermal energy balance

Derived Treatment Information

Computerized treatment record

Blood pressure and heart rate

Dialyzer clearance, delivered urea Kt/V , access blood flow rate

Relative change in blood volume

Maintenance of a constant body temperature

Safety Monitors in Hemodialysis

□ Dialysate Circuit

- ▣ Prepare the dialysate solution for safe exposure to the patient's blood
- ▣ Monitor the dialysate for conductivity and temperature
- ▣ Circulate the dialysate through the dialyzer
- ▣ Regulate ultrafiltration by volumetric control of the dialysate
- ▣ Monitor the effluent dialysate for blood leaks prior to going to the drain

□ Blood Circuit

- ▣ Circulate the blood outside the body through the dialyzer
- ▣ Anticoagulate the patient's blood
- ▣ Maintain blood in a sterile state
- ▣ Monitor the extracorporeal blood circuit for arterial and venous pressures and the integrity of the circuit for the presence of air and blood leaks

Control Panel and Monitor Display

NORMAL WARNING ALARM



POWER



RESET



MUTE



AIR BLOOD ARTERIAL VENOUS

MINOR

PRIME OVERRIDE

The main monitor display features two vertical scales. The left scale is labeled 'ARTERIAL' and ranges from -300 to 290. The right scale is labeled 'VENOUS' and ranges from -50 to 500. There are also horizontal bars for 'AIR', 'BLOOD', and 'MINOR'. Below the scales are two buttons labeled 'PRIME' and 'OVERRIDE'.

BP	10.00 AM	130/85	64
GOAL	4000	FLOW	800
TIME	4:00	TEMP	37.5
RATE	1000	COND	14.0
RMVD	0	RTD	0.00
TMP	14	BVP	2.5

TEST



UF ON/OFF



DFR ON/OFF



BYPASS



NA VAR



Monitor Failure

- All monitors can fail (mechanical, electrical or combination)
 - ▣ *Murphy's law: If anything can go wrong, it will*
- Machine monitors are frequently thought to be fail-safe devices, but they are not.
 - ▣ *A truly fail-safe device cannot be overridden to cause harm either by electronic or human intervention – obviously not the case in hemodialysis*
- Because all dialysis machine monitors can fail, they ought to be simple to operate and accurate—and should signal a warning when they are out of limits or not working properly.
 - ▣ *Human factors engineering principles*
- Any important factor requires dual monitoring: the machine monitor device and dialysis personnel.
 - ▣ *No machine, computer, or device can replace the continuous surveillance of hemodialysis personnel.*

Dialysate Circuit

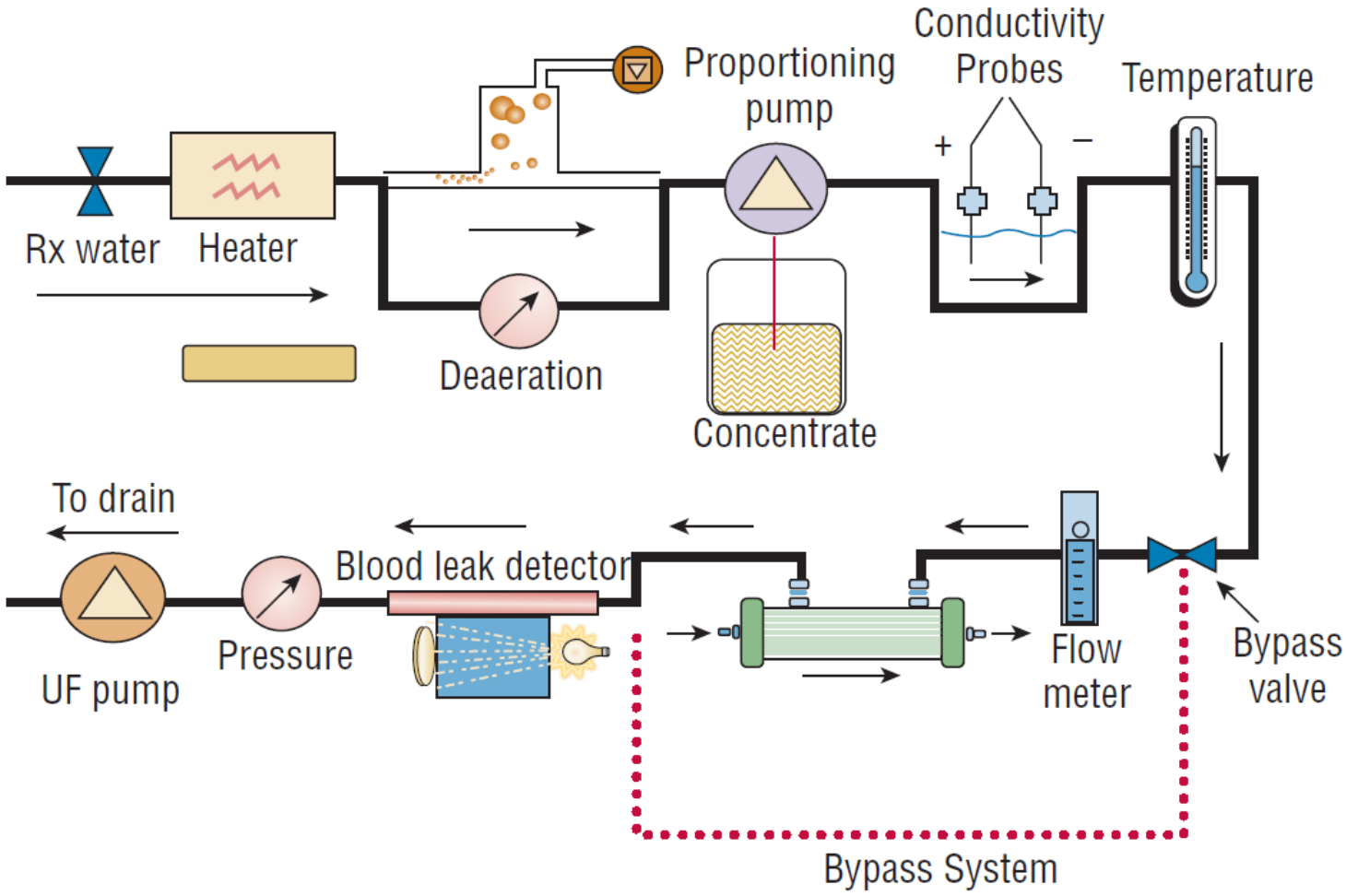

Dialysis Monitoring

- Heater monitoring
 - ▣ Thermistor feedback circuit usually controls electrical heating elements
 - ▣ Heater may have a coarse adjustment control inside the machine and a fine adjustment control on the front panel
- Deaeration monitoring
 - ▣ Observable by eye and relies on vacuum pump and proper interconnects
 - ▣ hidden cause of several serious dialysis problems, such as False blood-leak alarms, False conductivity alarms, Interference with volumetric control function, Decreased dialysis efficiency

Dialysis Monitoring

□ Mixing Device Monitoring

- Typical mixing ratios of *water* to *dialysate* concentrate are:
 - • 34:1 or 44:1 for acid concentrate
 - • 20:1 or 25:1 for bicarbonate concentrate
- If acid and bicarbonate inputs are reversed, or if the wrong concentrates are used for a bicarbonate machine, the servo loops may make a solution of acceptable ionic strength (correct conductivity) but of lethal ionic composition.
- In this case, the pH monitor or concentrate pump speed monitor becomes critical – However, not all machines are equipped with pH monitors

Monitoring Conductivity

- Conductivity measurement is an estimate of total ionic content of dialysate, and does not measure or reflect specific ions
- Conductivity meters usually read the conductivity in millimhos per cm (mmhos/cm) or milliSiemens per cm (mS/cm).
 - ▣ Upper and lower set values must be monitored

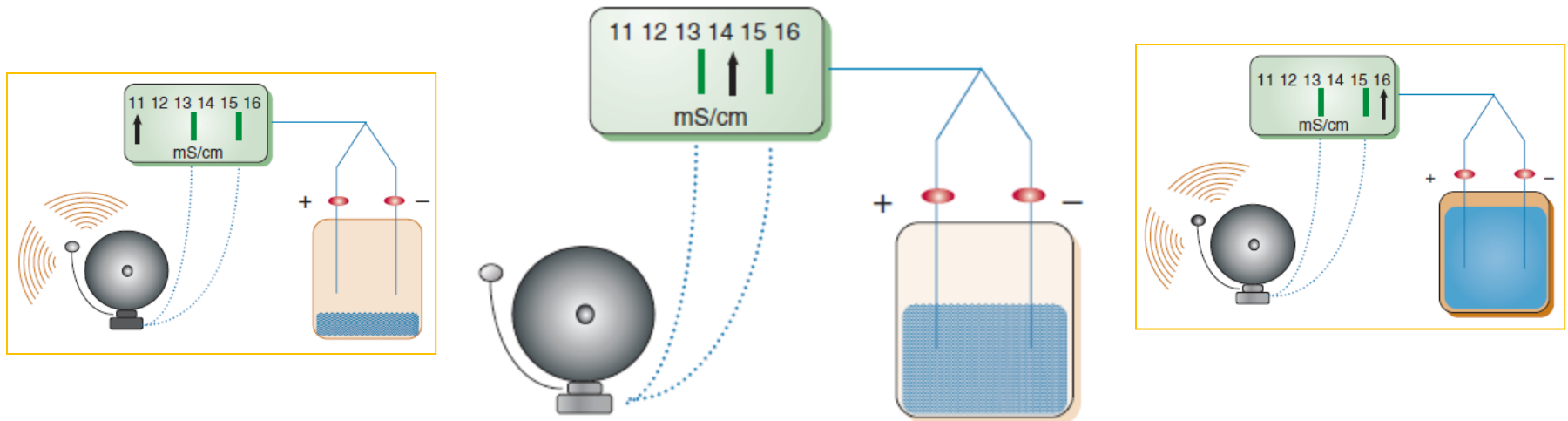

Bypass System, Monitoring, and Rinse Mode

- Bypass system diverts dialysate directly to drain away from dialyzer to avoid exposure of patient blood to unsafe dialysate
 - ▣ Activated by high/low conductivity, high/low pH, or high/low temperature
- Rinse mode on dialysis machines overrides the bypass system. It allows rinsing and disinfection of the entire fluid pathway.
 - ▣ Should never be activated while a patient is on dialysis.
 - ▣ In newer-model machines, the blood pump cannot be activated when the machine is in the rinse mode

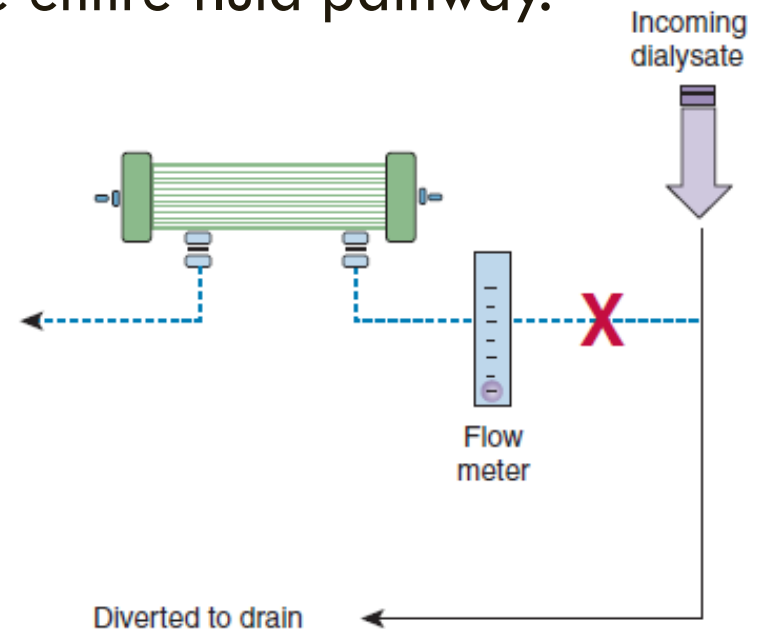

Dialysate Temperature

- Should be maintained between 37 and 38°C
- High limit should be set at no higher than 41°C
 - ▣ Normal red blood cells (RBCs) begin to hemolyze at 42°C
 - ▣ Overheated dialysate has been known to precipitate cardiac arrhythmias

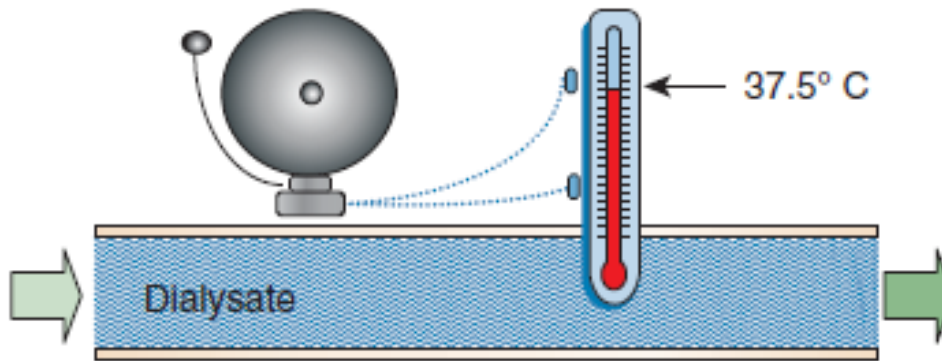

Blood-Leak Detector and Monitoring

- This monitor functions by transmitting filtered or unfiltered light through a column of effluent dialysate that exited dialyzer
 - ▣ Tears or leaks in the dialyzer membrane cause RBCs to leak into the dialysate, interrupting the light transmission
 - ▣ Machine response to a blood-leak alarm is to effect audible and visual alarms, stop the blood pump, and engage the venous line clamp

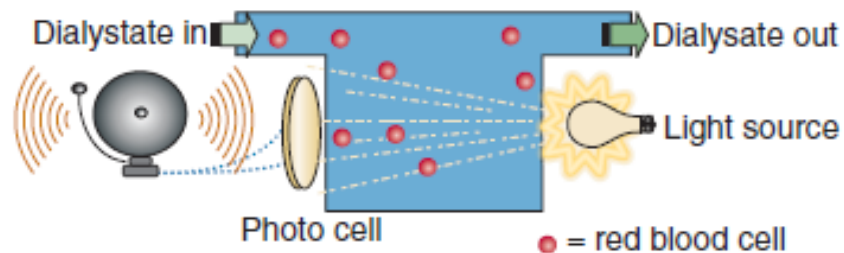
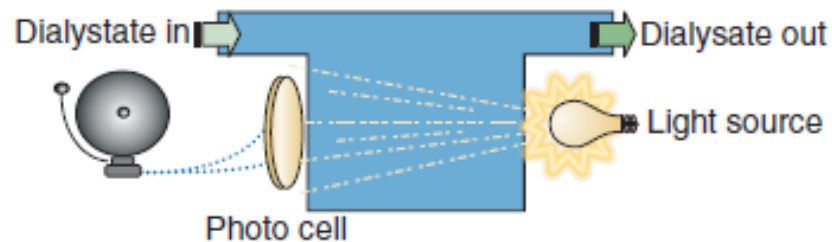

Blood Circuit

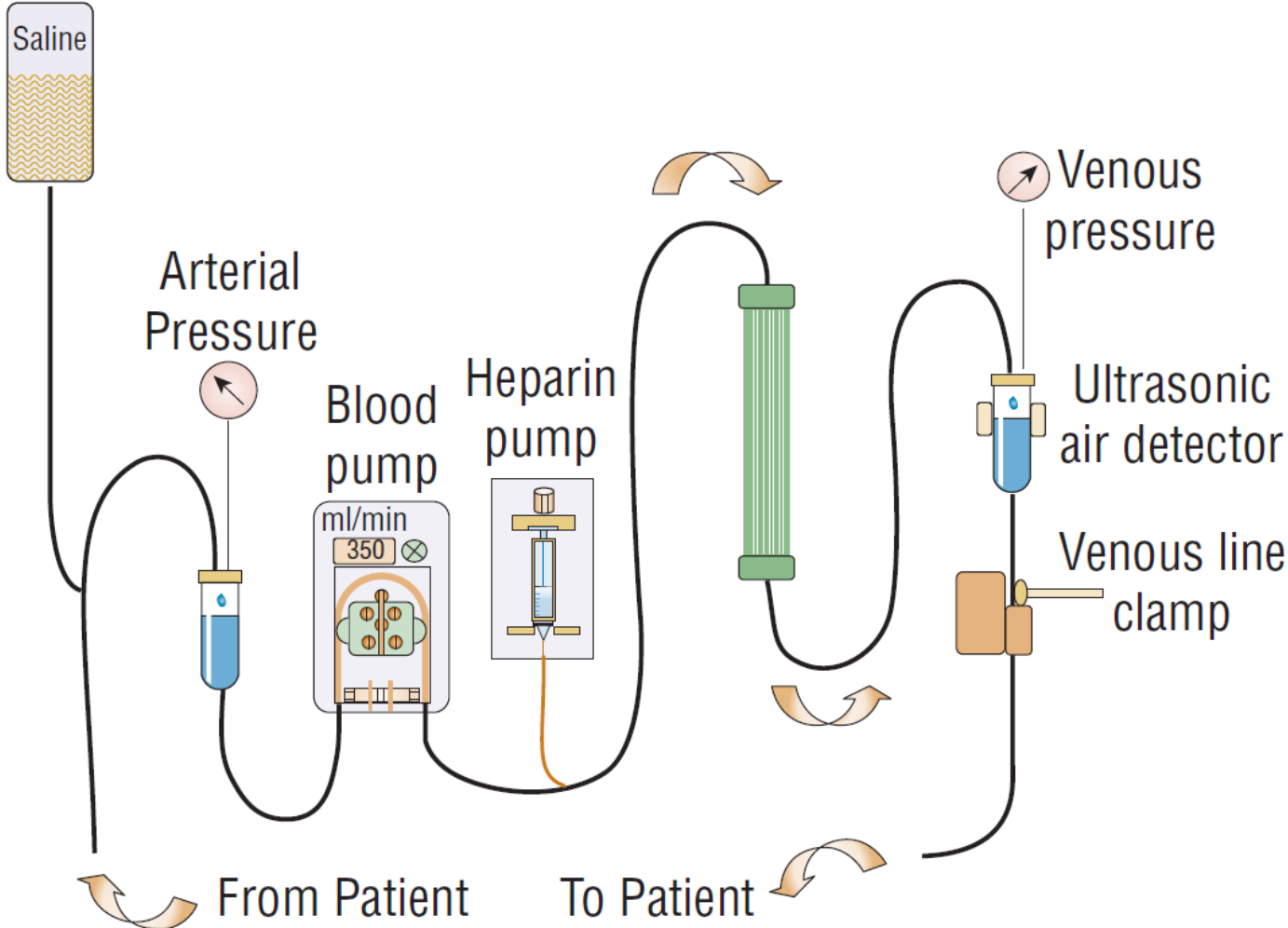

Arterial / Venous Pressure Monitors

- Arterial pressure monitor is leak free with adjustable high/low limits
 - ▣ reads negative and positive pressures in mmHg (10% accuracy)
 - ▣ During setup, priming, and rinsing of the dialyzer, the high/low limits are opened
- Venous pressure monitor, located post-dialyzer, monitors pressure at the venous drip chamber, the segment between the drip chamber and the patient's venous access

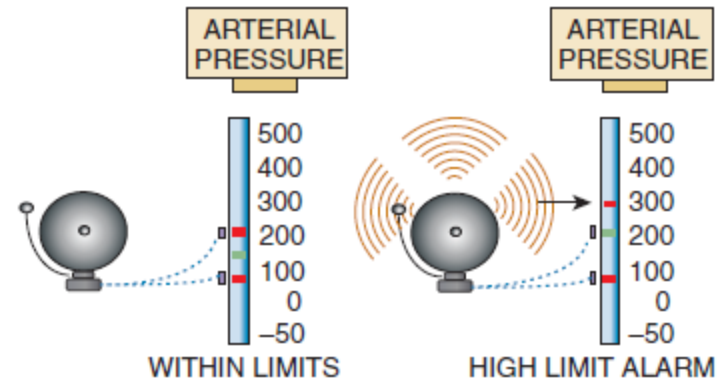
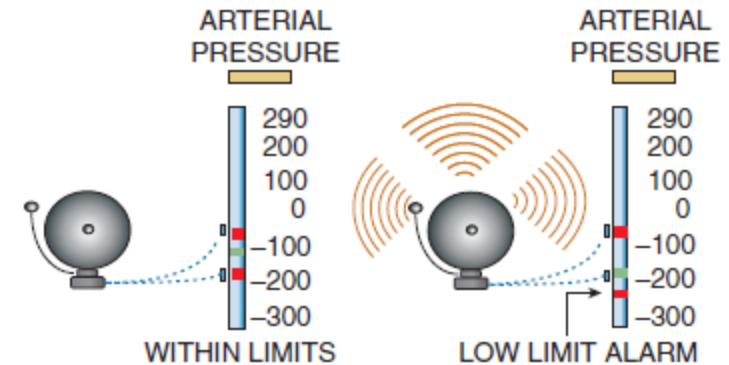

Air-Foam Detector and Venous Clamp

- Air-foam detector monitors blood in the venous tubing for the presence of air, foam, and microbubbles
- Two types of air-foam detectors are in use
 - ▣ Ultrasonic and reflected light detectors
 - ▣ Ultrasonic type is currently being sold in all new machines
- An air detector alarm must activate the venous clamp
 - ▣ Venous clamp must completely occlude venous bloodline and withstand an intraluminal pressure of 800 mmHg
 - ▣ Venous line clamp should be constructed as to not damage the bloodlines, and should not restrict the blood tubing open

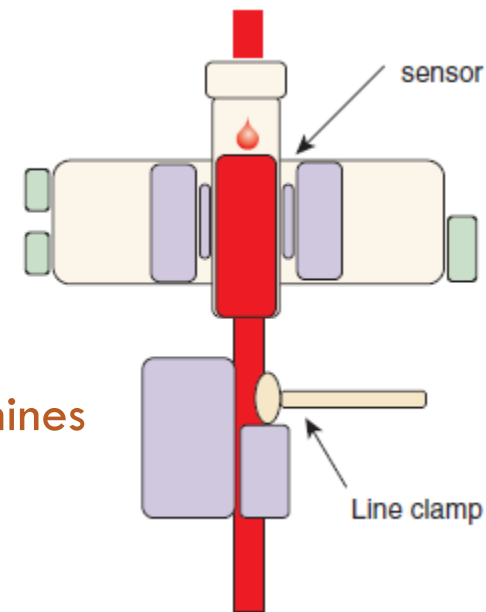

ANSI/AAMI RD5:2003/(R)2008

Condition	Equipment response	Document reference
1) Dialysate temperature (above 42 °C)	Audible and visual alarms; interrupt delivery of dialysate to hemodialyzer; stop blood flow in the extracorporeal circuit	4.2.4.2
2) Transmembrane pressure	Audible and visual alarms; minimize ultrafiltration	4.2.4.3
3) Blood circuit pressure (high or low)	Audible and visual alarms; shut off blood pump; clamp venous return line or otherwise prevent air from reaching the patient; minimize ultrafiltration	4.2.4.5
4) High or low dialysate conductivity	Audible and visual alarms; interrupt delivery of dialysate to hemodialyzer and/or stop blood flow in the extracorporeal circuit	4.2.4.6 (Not applicable to batch systems)
5) Blood leak	Audible and visual alarms; shut off blood pump; minimize ultrafiltration	4.2.4.7
6) Blood circuit air protection	Audible and visual alarms (for alarm conditions or when monitor has not been activated and patient is connected to the dialysis machine); turn off blood pump to prevent air in venous bloodline from reaching patient (alarm condition only, to prevent pressure in the blood circuit from forcing air toward the patient); minimize ultrafiltration	4.2.4.8
7) Disinfection protection	Visual alarm; prevent dialysis of patient	4.2.4.9
8) Ultrafiltration control/monitor	If monitored, audible and visual alarms should be included indicating nature of malfunction	4.2.4.4
9) Power failure	Audible alarm	4.4.2(5)

Ultrafiltration Control Design Problem

- For a device to be considered an “ultrafiltration control” system, it must function with an overall accuracy of $\pm 5\%$ of the selected ultrafiltration rate or ± 100 mL/h, whichever is greater, over the specified range of operation
- Consider the design using 2 flowmeters
 - ▣ $UF = Flow1 - Flow2$
 - ▣ $Error(UF) (mL/h) = Error(Flow1) (mL/h) + Error(Flow2) (mL/h)$
 - ▣ Flow range in Flow1 & Flow2: 1 L/min
 - ▣ Ultrafiltration range: 1 L/hr
 - ▣ Must have extremely high precision flowmeters

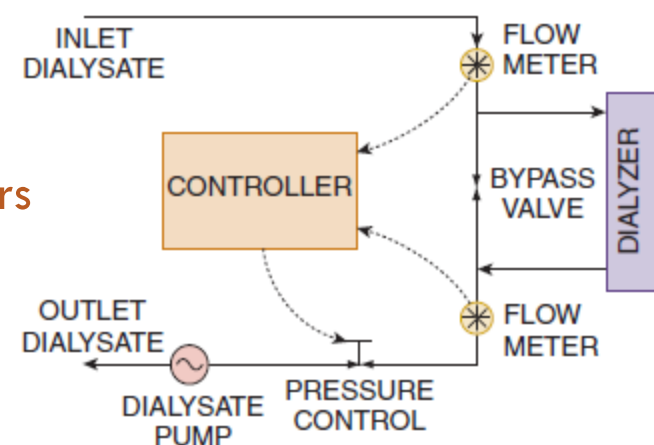

Covered Material

- Chapters 10 & 12 of Dialysis handout