

Medical Analytical

MINIATURE
SOLENOID VALVES

ASCO
SCIENTIFIC®

Medical

Medical equipment designed and used for preventive, diagnostic and therapeutic purposes employs many different technologies. Efficient control of the gaseous fluids and liquids contributes to equipment performance, treatment quality and comfort of the patient.

Multi-function modules:

- solenoid valves (shut-off and/or proportional), pressure sensors, etc.
- special connections and manifold / subbase mounting
- optimised performance

ASCO/JOUCOMATIC incorporates these and other requirements in the development of dedicated products.

• Reliability

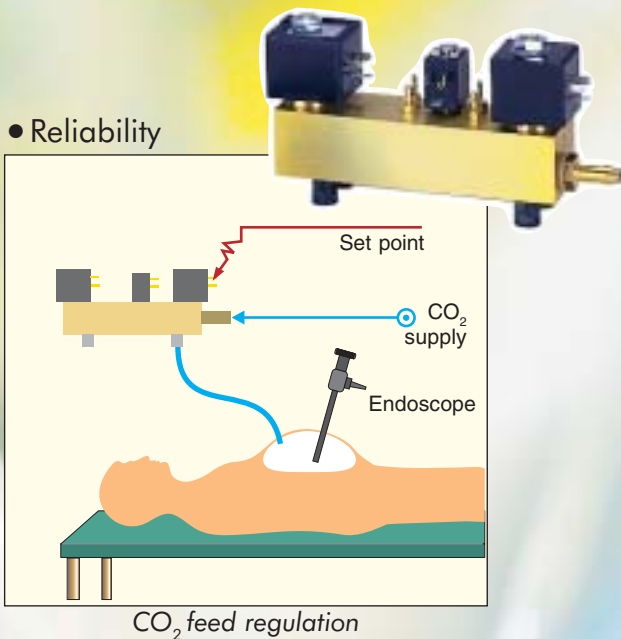

• Miniaturisation



• Low electric power consumption



• Full compatibility with your fluids

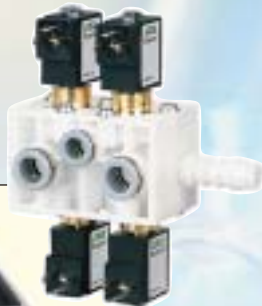

Respirator

Analytical

BIOMEDICAL ANALYSES

More than any other health care domain, medical biology represents a leading edge sector in a state of constant mutation and is frequently the starting point for therapeutic innovation. The development of new methods and materials meets the demands of the practitioner in terms of test diversity, while ensuring the reliability and rapid acquisition of result data and effective cost control. Automation and miniaturisation are steadily taking over in the five principal biomedical domains of haematology, biochemistry, immunology, immunochemistry and microbiology.



Haematological analyser



Rocker type solenoid valve



Automatic analyser



Pinch type solenoid valve for ultra-pure fluids

INDUSTRIAL APPLICATIONS

Numerous sectors (agro-business, energy, environment, chemicals, pharmaceuticals, cosmetics, etc.) use industrial analysis equipment for process control, measurement, detection, regulation, metering and other applications.



Physiochemical analyses



Air analyser



Bellows solenoid valve

5 Fluid isolation

Many applications require total absence of contact between the fluid (liquid or gas) and the internal parts of the solenoid valve (control system) to:

- **ensure total prevention of contamination** from particles of material from moving parts,
- **minimise heat transfer** from the electromagnetic part, and
- **ensure a high level of reliability** for the solenoid valve for handling extremely aggressive fluids.

The five fluid isolation technologies used in our range of solenoid valves provide relevant answers to your requirements through their specific characteristics and performance.

DIAPHRAGM

- Low electric power consumption
- Small dead volume
- Quick response time

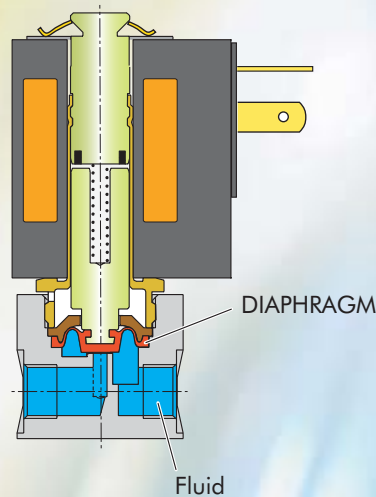

ROCKER

- Miniature solenoid valve
- Small dead volume
- Laboratory or industrial type connections
- Battery control possible

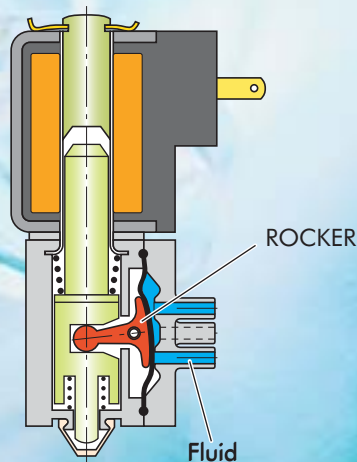

technologies

LEVER

- High flow rate
- Laboratory or industrial type connections
- Easy to disassemble
- Minimum heat transfer to fluids

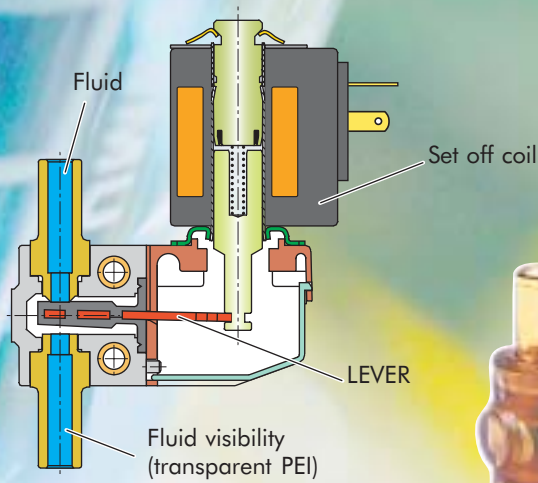

TUBE PINCH

- Miniature solenoid valve
- Ultra-pure fluids
- Low electric power consumption
- Battery control possible

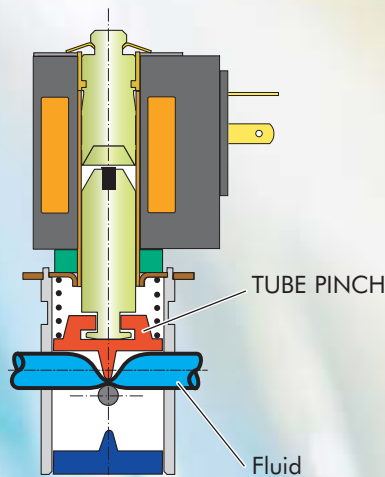

BELLOWS

- Highly aggressive fluids
- Industrial type connections

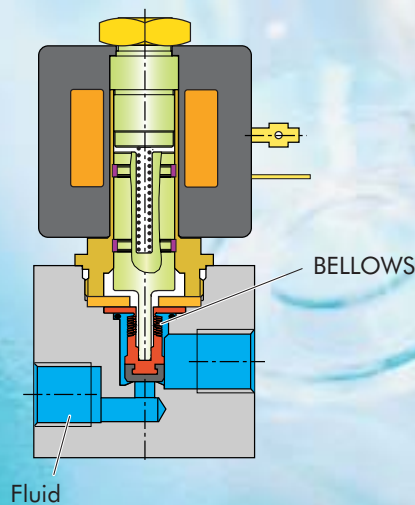



ASCO SCIENTIFIC®

ASCO SCIENTIFIC is the brand name under which ASCO/JOUCOMATIC, a world leader in the solenoid valve field, markets five fluid isolation product ranges for the **medical, biomedical and industrial analysis markets**. Where standard products no longer provide the answer, our wealth of expertise and experience enables us to design and develop dedicated solenoid valves and multi-function modules to meet your particular needs.

The ASCO SCIENTIFIC catalogue of miniature solenoid valves includes these ranges together with a selection of components (shut-off and proportional solenoid valves, etc.) from the ASCO/JOUCOMATIC comprehensive range, and presents a global, personalised product package matching your **particular requirements**.

All our products – valves, solenoid valves and pneumatic components and fittings – are on show at : www.ascojoucomatic.com.

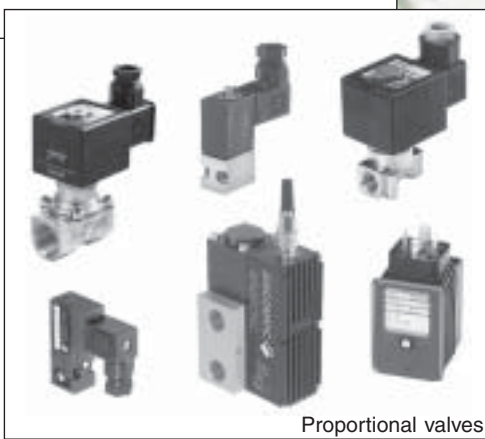

S U M M A R Y

Isolation valves

Series 110 - 2/2-3/2, rocker, hose connections	X006-01-01
Series 360 - 3/2, rocker, threaded connections	X006-01-05
Series 360 - 2/2-3/2, rocker, pad mounting	X006-01-07
Series 385 - 3/2, rocker, pad mounting	X006-01-09
Series 282 - 2/2, diaphragm, M5 - 1/8 - 1/4	X006-01-11 / 13
Series 283 - 2/2, lever, smooth spigots, Ø ext. 8 - 11 mm	X006-01-15 / 19
Series 383 - 3/2, lever, threaded connection, 1/4 - 1/2	X006-01-17 / 21
Series 296 - 2/2, bellows, 1/8 - 1/4	X006-01-23
Series 396 - 3/2, bellows, 1/4	X006-01-25

Pinch valves

Series 284 - 2/2, NC	X006-02-01
Series 284 - 2/2, NO	X006-02-03
Series 384 - 3/2, U	X006-02-05

Non isolation valves

Series 108 - 2/2, pad mounting	X006-03-01
Series 109 - 3/2, pad mounting	X006-03-03
Series 188 - 3/2, micro 10 range	X006-03-05
Series 302 - 3/2, pad mounting	X006-03-09

Proportional valves

Series 630 - 2/2, Piezotronic	X006-04-01
Series 202 - 2/2, pad mounting	X006-04-03
Series 202 - 2/2, 1/8	X006-04-05
Series 202 - 2/2, 1/4	X006-04-07
Series 202 - 2/2, 3/8	X006-04-09
Series 203 - 2/2, 3/8 - 1/2	X006-04-11
Series 908 - Electronic proportional control unit	X006-04-13
Series 601 - Sentronic Servovalve, 1/8 to 1	X006-04-15

Accessories

Connectors	X006-05-01
------------	------------

Specialised products

Multi-function modules	X006-06-01
Solenoid valves	X006-06-02

General information

Solenoid valve terminology	X006-07-01
Definitions	X006-07-02
Materials	X006-07-03
Fluid resistance guide	X006-07-04
Valve requirement check list	X006-07-05
Conversion table	X006-07-06